



211 HIGHLAND CROSS DRIVE • SUITE 220 • HOUSTON, TEXAS 77073  
PHONE: (281) 209-1724 • FAX: (281) 209-2724 • TOLL FREE (800) 966-6088

# PROJECT MANUAL ROOF REPLACEMENT

FOR  
UNIVERSITY OF TEXAS HEALTH SCIENCE CENTER  
SCHOOL OF NURSING  
6901 BERTNER  
HOUSTON, TEXAS



PREPARED BY  
PRICE CONSULTING, INC.  
211 HIGHLAND CROSS DRIVE, #220  
HOUSTON, TEXAS 77073

TEXAS REGISTERED ENGINEERING FIRM NO. F-3814

PCI PROJECT NO. 11204.15  
APRIL 19, 2016



**DOCUMENT 00 00 02**

**PROJECT DIRECTORY**

**PROJECT:** School of Nursing (SON): Roof Replacement  
6901 Bertner  
Houston, Texas

**OWNER:** University of Texas Health Science Center/Houston  
7000 Fannin Street  
JCT M125  
Houston, Texas 77030  
Contact: Ms. Laura Berbel, Sr. Project Manager  
Office: (713) 500-3427  
Email: Laura.D.Berbel@uth.tmc.edu

**CONSULTANT/ENGINEER:** Price Consulting, Inc.  
211 Highland Cross Drive  
Suite 220  
Houston, Texas 77073  
Contact: Mr. Karl A. Schaack, P.E., RRC  
Office: (281) 209-1724  
Cell: (281) 827-9250  
Email: kschaack@priceconsulting.com

**END OF PROJECT DIRECTORY**

**DOCUMENT 00 00 30**

**TABLE OF CONTENTS**

Document 00 00 10 - Title Page	1 page
Document 00 00 20 - Project Directory	1 page
Document 00 00 30 - Table of Contents	1 thru 2
Document 00 00 40 - Index of Drawings	1 page

**SPECIFICATIONS**

**Division 1 - General Requirements**

<u>Section</u>	<u>Page #</u>
01 01 00 - Summary of Work	1 thru 3
01 02 60 - Unit Prices	1 thru 2
01 03 00 - Alternates	1 page
01 07 50 - Definitions	1 thru 3
01 12 00 - Alterations Project Procedures	1 thru 4
01 20 00 - Project Meetings	1 thru 2
01 30 00 - Submittals	1 thru 4
01 40 00 - Quality Control	1 thru 2
01 43 00 - Mock Ups	1 page
01 50 00 - Temporary Facilities and Controls	1 thru 4
01 60 00 - Material and Equipment	1 thru 3
- Substitution Request Form	1 thru 3
01 70 00 - Contract Closeout	1 thru 2
01 71 00 - Cleaning	1 thru 2

**Division 2 - Sitework**

<u>Section</u>	<u>Page #</u>
02 07 20 - Minor Demolition and Renovation Work	1 thru 9

**Divisions 3 thru 6 - NOT USED**

**Division 7 - Thermal and Moisture Protection**

<u>Section</u>	<u>Page #</u>
07 22 00 - Roof and Deck Insulation	1 thru 5
07 52 50 - Modified Bitumen Membrane Roofing	1 thru 12
07 62 00 - Sheet Metal Flashing and Trim	1 thru 10

**Divisions 8 thru 25 - NOT USED**

**Division 26 - Electrical**

**THE UNIVERSITY OF TEXAS HEALTH SCIENCE CENTER  
SCHOOL OF NURSING  
HOUSTON, TEXAS**

---

Section  
26 41 00 - Lightning Protection System

Page #  
1 thru 3

**Divisions 27 thru 33 - NOT USED**

**DOCUMENT 00 00 40**

**INDEX OF DRAWINGS**

SHEET R1.00  
SHEET R1.01  
SHEET R2.00  
SHEET R2.01  
SHEET R2.02  
SHEET R2.03  
SHEET R2.04  
SHEET R2.05  
SHEET R5.00  
SHEET R5.01  
SHEET R5.02  
SHEET R5.03

COVER SHEET  
GENERAL NOTES  
EXISTING ROOF PLAN  
ROOF PHASING PLAN  
OVERALL NEW ROOF PLAN  
PARTIAL NEW ROOF PLAN  
PARTIAL NEW ROOF PLAN  
PARTIAL NEW ROOF PLAN  
DETAILS  
DETAILS  
DETAILS  
DETAILS

**END OF INDEX OF DRAWINGS**

**SECTION 01 01 00**

**SUMMARY OF WORK**

**PART ONE - GENERAL**

**1.01 SECTION INCLUDES:**

- A. Roof replacement and roof related renovations of the existing facility known as the School of Nursing located at 6901 Bertner in Houston, Texas. Work includes, but is not limited to, the following:
  - 1. Remove and properly dispose of existing roofing, insulation, and sheet metal down to the existing concrete deck or fluted steel deck on designated roof areas.
  - 2. Remove abandoned equipment, curbs, and/or penetrations and repair openings in deck.
  - 3. Install flat-stock polyisocyanurate insulation board set in low-rise foam adhesive on concrete deck or mechanically attached to fluted steel deck.
  - 4. Install tapered polyisocyanurate insulation board set in low-rise foam adhesive over base layer of insulation.
  - 5. Install gypsum roof cover board in low-rise foam adhesive.
  - 6. Install two-ply modified bitumen roof membrane.
  - 7. Install new modified bitumen flashings and sheet metal flashing at parapet walls, rise walls, equipment curbs, and penetrations.
  - 8. Install new sheet metal flashings along roof perimeters, rise walls, curbs, and penetrations.
  - 9. Install new sheet metal coping on parapet walls.
  - 10. Install new walk pads at roof access areas, around equipment, and at high-trafficked areas and as required by Owner.
  - 11. Disconnect roof-top lightning protection system to install new roofing system and re-install upon completion of new roof system installation.
  - 12. Provide specified contractor and manufacturer warranties.

**1.02 WEATHER PROTECTION:**

- A. Upon beginning work on the existing roof, Contractor shall patch and protect existing roofing as required to prevent leaks.
- B. Contractor shall have at the work site, a sufficient amount of moisture proof coverings to provide quick temporary protection to exposed decking, unfinished roof, or open roof in the event of a rapid change in the weather.

**1.03 CONTRACTOR'S USE OF PREMISES:**

- A. Confine operations at site to areas permitted by law, ordinances, permits and to limits of Contract as shown on Contract Documents.
- B. Do not unreasonably encumber site with materials or equipment.
- C. Do not load structure with weight that will endanger structure.

**THE UNIVERSITY OF TEXAS HEALTH SCIENCE CENTER  
SCHOOL OF NURSING  
HOUSTON, TEXAS**

---

- D. Assume full responsibility for protection and safekeeping of products stored on premises.
- E. Move stored products which interfere with operations of Owner.
- F. Obtain and pay for use of additional storage or work areas needed for operations.
- G. Coordinate use of premises under direction of Owner's Representative.
- H. Use of Site for Work and Storage:
  - 1. Restrict Work to areas indicated on Drawings.
  - 2. Store materials off site except for minor amounts of material which may be stored at designated staging area as approved by Owner.
  - 3. Access site in areas approved by Owner.
  - 4. Restrict parking to specific areas as approved by Owner.
  - 5. Restrict debris removal to Owner-approved area of building site.
  - 6. Restrict location of construction cranes to areas as approved by Owner.
  - 7. Do not allow construction traffic on existing roof membrane except as absolutely necessary to perform new work. Provide protection such as plywood/sheathing and plastic sheeting over existing roof membrane at traffic and work areas.
- I. Maintenance of Access and Operations:
  - 1. Do not perform operations that would interrupt or delay Owner's daily operations.
  - 2. Maintain access to existing building, facilities, parking, streets, and walkways; especially fire lanes.
  - 3. Schedule demolition and renovation operations with Owner in such a manner as to allow Owner operations to continue with minimum interruption.
  - 4. During period of construction, do not obstruct exit ways of Owner-occupied areas in any manner.
- J. Maintenance of Existing Services:
  - 1. Do not disrupt existing utility services to existing building.
  - 2. Maintain environmental control in existing building, especially temperature, humidity, and dust control.
  - 3. Provide temporary lines and connections as required to maintain existing mechanical and electrical services in building.
  - 4. Gas piping at rooftop units may be temporarily disconnected (maximum four hours) to raise piping and replace flashing. Maintain cooling operation of unit during this period.
  - 5. Notify Owner a minimum of two days prior to each required interruption of mechanical or electrical services in building. These interruptions shall be only at such times and for lengths of time as approved by Owner. In no event shall interruption occur without prior approval of Owner.
- K. Building Access:
  - 1. Access to roof construction areas shall be by way of route as designated by Owner.
  - 2. Contractor will not have access to building interior except as pre-arranged with Owner.

**THE UNIVERSITY OF TEXAS HEALTH SCIENCE CENTER  
SCHOOL OF NURSING  
HOUSTON, TEXAS**

---

**1.04 OWNER OCCUPANCY:**

- A. Owner will occupy premises during entire period of construction for the conduct of normal, daily operations. Cooperate with Owner's Representative in all construction operations to minimize conflict and to facilitate Owner usage.
- B. Contractor shall conduct his operations so as to ensure least inconvenience to Owner's operations.
- C. Contractor shall take precautions to avoid excessive noise or vibration that would disturb Owner's operations. When directed by Owner, Contractor shall perform certain operations at designated time of day or night in order to minimize disturbance to Owner's operations.
- D. Contractor shall take all necessary precautions to assure a watertight condition in the operation portion of the building during construction.
- E. Refer to Section 01 12 00 for provisions on security, special sequence of Work, maintenance of access and operations, maintenance of existing utilities and services, and building access restrictions.

**PART TWO - PRODUCTS**

Not Used.

**PART THREE - EXECUTION**

Not Used.

**END OF SECTION 01 01 00**



SECTION 01 02 60

UNIT PRICES

PART ONE - GENERAL

1.01 SECTION INCLUDES:

- A. Unit prices for calculation of work, complete in place, to be added or deleted from the project.

1.02 MEASUREMENT AND PAYMENT:

- A. It is the intent of the Bid Form that aggregate bid amount as submitted shall cover work required by Contract Documents in place, complete, and ready for use.
- B. Unit prices include costs to fully complete work in place, including providing labor, materials, tools, equipment, services, supplies, incidentals, necessary operations, profit, taxes, overhead, maintenance, and warranties.
- C. No costs in connection with work required by Contract Documents for proper and successful completion of Contract will be paid outside of or in addition to prices submitted.
- D. Work not specifically set forth as pay items shall be considered subsidiary obligations of Contractor and costs shall be included in prices named.
- E. Method of measurement and basis of payment shall be as stipulated in following paragraphs.

PART TWO - PRODUCTS

Not Used.

PART THREE - EXECUTION

3.01 UNIT PRICE ITEMS:

<u>Item</u>	<u>Unit</u>
1. Wood Nailers:	
2 x 4 wood nailer:	\$ _____ per linear foot
2 x 6 wood nailer:	\$ _____ per linear foot
2 x 8 wood nailer:	\$ _____ per linear foot
2 x 12 wood nailer:	\$ _____ per linear foot

**THE UNIVERSITY OF TEXAS HEALTH SCIENCE CENTER  
SCHOOL OF NURSING  
HOUSTON, TEXAS**

---

2. Roof Deck: Remove, replace, and/or repair damaged/deteriorated decking, matching existing type, weight, gauge, and dimension:

- a. Concrete Deck Repair: \$ \_\_\_\_\_ per square foot
- b. Fluted Steel Deck Replacement: \$ \_\_\_\_\_ per square foot
- c. Fluted Steel Deck Prepare/Paint: \$ \_\_\_\_\_ per square foot

3. Replace existing roof drain: \$ \_\_\_\_\_ each

**3.02 AUTHORIZATION, RECORD KEEPING, AND PAYMENT FOR UNIT PRICE ITEMS:**

- A. Consultant's Field Representative will authorize Contractor when Unit Price Items are to be installed by Contractor. No payment will be made for any Unit Price Items installed by Contractor that is not authorized by Consultant's Field Representative or Owner.
- B. Consultant's Field Representative will maintain a record of all installed Unit Price Items and this record shall be utilized to produce the Change Order to include the Unit Price Items in Contractor's contract.

**END OF SECTION 01 02 60**

**SECTION 01 03 00**

**ALTERNATES**

**PART ONE - GENERAL**

**1.01 DESCRIPTION:**

- A. Identification of Alternate by number and description of basic changes to be incorporated into the Work only when that Alternate is made part of Work by specific provisions in the Owner-Contract Agreement.
- B. Alternates, as described below, add work to or deduct work from the Base Bid.
- C. These Specifications or Drawing Details stipulate pertinent requirements for products and methods to achieve the Work stipulated under each Alternate.
- D. Coordination of pertinent related Work and modification surrounding Work as required to properly integrate Work under each Alternate and to provide the complete construction required by Contract Documents.

**1.02 DESCRIPTION OF ALTERNATES:**

- A. Alternate No. 1: Replace roofs designated as Area "B".
- B. Alternate No. 2: Replace roofs designated as Area "C".

**PART TWO - PRODUCTS**

Not Used.

**PART THREE - EXECUTION**

Not Used.

**END OF SECTION 01 03 00**

**SECTION 01 07 50**

**DEFINITIONS**

**PART ONE - GENERAL**

**1.01 SECTION INCLUDES:**

- A. Definitions for construction terminology not otherwise defined in Contract Documents.
- B. Definitions for special terminology used for this Project.

**1.02 ABANDONED - (NO LONGER NECESSARY OR IN USE):**

- A. "Remove" items so noted, or later defined, as an all inclusive responsibility within this contract. Pay for all work in connection with removal of these items, including municipal, disposal, utility, and service charges. Dispose of all "Excess".

**1.03 ADDITION - (TO ADD TO AND BE INCORPORATED) ALSO TO "ADD":**

- A. Work supplementary to that indicated to accomplish that which is required by the Contract Documents. To bring to a new condition; to extend, fasten, patch, and match to that which is existing.

**1.04 DEFECTIVE - (NOT ACCEPTABLE):**

- A. Refer to Conditions of the Contract, that which does not conform to the Contract Documents. As it applies to "Salvage", in addition to the above, shall mean "unsuitable".

**1.05 EXCESS - (NOT REQUIRED):**

- A. More quantity than required to conform to the Contract Documents and not desired by the Owner. Debris shall be considered "Excess" and not be used as fill or be buried on this site. Remove "Excess" from the site and legally dispose of. "Excess" "Suitable" "Salvage" shall be property of Contractor unless otherwise specified.

**1.06 EXISTING - (PRESENTLY THERE):**

- A. Also may be noted "original". Present conditions and assumed locations, if known, as of the Date of Contract Documents.

**1.07 NEW - (TO BE INCORPORATED) NOT EXISTING:**

- A. Refer to various specification sections for requirements of Work to be incorporated.

**1.08 REINSTALL - (TO INCORPORATE AS WAS ONCE DONE):**

- A. "Remove" and "salvage" existing from its location, if it does exist. "Restore", "Renovate", or "Remodel" and "Reinstall: in its existing location. Reincorporate and "re-work" the original work to the extent required by the Contract Documents.
- B. If the "Existing" item, so indicated, is missing, defective, or unsuitable as "Existing", then "Reconstruct" only that portion with "New" products and incorporate as was original. Syn. Replace.

**1.09 RELOCATE - ("REINSTALL" IN A NEW LOCATION):**

A. "Reinstall" in a new location as indicated on Drawings.

**1.10 REMAIN - (TO LEAVE WHERE IT IS EXISTING):**

A. The final location of an item in its "existing" position, however, this shall not mandate the fact that this item will not move during this contract, specifically in order to "Preserve" or "Rework".

**1.11 REMOVE - (TO TAKE FROM EXISTING LOCATION):**

A. Work required to extract a portion or whole by one or a combination of methods and moved to a new location.

1. "Abandoned": Remove items by dismantling, excavation, extraction, or demolition, if acceptable.
2. Salvage: Remove by disassembly. "Relocate".
3. Products: Where a specific portion of component of an assembly or whole is to be removed, take all precautions to prevent damage, defacement, and displacement to the "existing" to remain (i.e., mortar, bricks, and finishes).

**1.12 RENOVATE - (TO REPAIR AND MAKE NEW):**

A. The process required to bring an item to a present new standard of condition required by the Contract Documents (e.g., to "rework" "existing" "suitable" "salvage" "products" and perform "new" work and "additions" required). (Syn. rehabilitate, recondition, repair.)

**1.13 REPLACE - (TO TAKE THE PLACE OF):**

A. "Remove" "existing" unserviceable product and provide "new" product in place of unserviceable product.

**1.14 REUSE - (TO USE AS ONCE WAS):**

A. The use of "suitable" "salvage" for incorporation or re-incorporation in the Work. "Remove", "Relocate", and "Reinstall" as required for "Reuse".

**1.15 SALVAGE - (TO BECOME ABANDONED):**

A. "Remove", protect, "preserve" incomplete material condition as found "existing". Also to "Save". Determine suitability for incorporation in this Contract. Store at a location mutually agreed upon. Dispose of all "Excess".

**1.16 UNKNOWN - (NOT SHOWN ON DRAWINGS):**

A. Products beneath surfaces indicated by drawings and encountered during the Work. Immediately support, shore, and protect. Immediately notify the Consultant and authority having jurisdiction. Allow free access for inspection. "Preserve" in proper condition until the Consultant determines definition and interpretation of Work. Take such measures as required for protection, reinforcement, or adjustment.

**PART TWO - PRODUCTS**

Not Used.

**PART THREE - EXECUTION**

Not Used.

**END OF SECTION 01 07 50**

**SECTION 01 12 00**

**ALTERATIONS PROJECT PROCEDURES**

**PART ONE - GENERAL**

**1.01 DESCRIPTION:**

- A. Summary: The procedures and administrative requirements of this Section apply to all of the following Sections of the Specification which are involved in alterations to the existing building.
- B. Extent Notes: Cut into or partially remove portions of the existing building as necessary to make way for new construction. Include such work as:
  - 1. Cutting, moving, or removal of items shown to be cut, moved, or removed.
  - 2. Cutting, moving, or removal of items not shown to be cut, moved, or removed, but which must be cut, moved, or removed to allow new work to proceed. Work or items which are to remain in the finished work shall be patched or reinstalled after their cutting, moving, or removal, and their joints and finishes made to match adjacent or similar work.
  - 3. Removal of existing surface finishes as needed to install new work and finishes.
  - 4. Removal of abandoned items and removal of items serving no useful purpose, such as abandoned piping.
  - 5. Repair or removal of dangerous or unsanitary conditions resulting from alterations work.

**1.02 SCHEDULING AND ACCESS:**

- A. Work Sequence: Contractor shall submit detailed project plan with work sequence and phasing schedule.
- B. Security:
  - 1. Be solely responsible for job site security.
  - 2. Protect completed work and stored items from vandalism and theft.
  - 3. Contact Owner for access to all security areas.
- C. Maintenance of Access and Operations:
  - 1. During period of construction, Owner will continue to perform normal activities in existing building. Maintain proper and safe access to Owner-occupied areas at all times.
  - 2. Schedule demolition and remodeling operations with Owner in such a manner as to allow Owner operations to continue with minimum interruption.
  - 3. During period of construction, do not obstruct existing exit ways of Owner-occupied areas in any manner.
- D. Maintenance of Existing Services:
  - 1. Maintain environmental control in existing building, especially temperature, humidity, and dust control.
  - 2. Provide temporary lines and connections as required to maintain existing mechanical and electrical services in building.
  - 3. Equipment handling shall be limited to Owner-approved hours and may be limited to night time hours.

4. Notify Owner a minimum of forty-eight hours prior to each required interruption of mechanical or electrical service in building. Such interruptions shall be only at such times and for lengths of time as approved by Owner. In no event shall interruption occur without prior approval of Owner.
- E. Temporary Barricades:
  1. Provide and erect barricades as necessary to protect ground personnel, employees, passersby, etc., from hazards resulting from the Work during construction operation.
  2. Prevent public access to construction activities, equipment, and storage areas.
- F. Building Access:
  1. Contractor will limit access to building interior except:
    - a. To install temporary enclosures, protections, and equipment.
    - b. For project or medical emergency.
  2. Access to roof construction areas shall be by way of Owner designated method.

### **1.03 ALTERATIONS, CUTTING AND PROTECTION:**

- A. Extent:
  1. Perform cutting and removal of deck work so as not to cut or remove more than is necessary and so as not to damage adjacent work.
  2. Conduct work in such a manner as to minimize noise and to minimize accumulation and spread of dirt and dust.
  3. Perform cutting for ductwork and other rectangular openings with carborundum saw with approved dust arrestor.
- B. Securement of Openings: Protect all openings made in existing roofs, etc., with barricades to prevent accidents to Owner's and Contractor's personnel. If required by Owner, provide a workman at ground level inside the building at all times during the tear-off operations and when the roof deck or roofing is being installed. It will be the responsibility of this individual to alert personnel in the area of the work being performed overhead, to watch for falling debris, and to broom clean the area each day of any dirt that may result from the roof replacement operations.
- C. Responsibility and Assignment of Trades:
  1. Contractor shall assign the work of moving, removal, cutting, patching, and repair to trades under his supervision so as to cause the least damage to each type of work encountered, and so as to return the building as much as possible to the appearance of new work.
  2. Patching of finish materials shall be assigned to mechanics skilled in the work of the finish trade involved.
- D. Protection:
  1. Protect remaining finishes, equipment, and adjacent work from damage caused by cutting, moving, removal, and patching operations. Protect surfaces which will remain a part of the finished work.
  2. Cover existing walls and floors where necessary to prevent damage from construction operations.



3. During demolition, cutting, and construction, provide positive dust control by wetting dusty debris and by completely sealing openings to Owner-occupied areas with temporary seals so as to prevent spread of dust and dirt to interior areas.
  4. After materials are installed, properly protect Work until final acceptance.
  5. Repair any damage resulting from construction operations without cost to Owner.
  6. Provide continuous security at openings cut into existing exterior walls and roofs during non-working hours. Prevent unauthorized entry into the existing facility through areas demolished or accessed as part of the Work.
- E. Special Protection:
1. Comply with welding and cutting precautions specified in Section 01 50 00 - Temporary Facilities and Controls. In addition, provide Type I fire retardant enclosure around area of welding.
  2. Provide temporary weather protection over open roof penetrations until final flashing is completed.
  3. During equipment handling, provide a roof applicator at project with sufficient materials for temporary patching and sealing.
  4. Provide roof applicator at jobsite continuously during rainstorms which may occur while job is in progress to make temporary or emergency repairs.
- F. Debris:
1. Remove debris from the site daily. Removed material becomes property of the Contractor. Load removed material directly on trucks for removal from site. Dispose of removed material legally. Do not allow debris to enter sewers.
  2. Do not allow material accumulations to endanger structure.
  3. Cover and secure material accumulations as necessary to prevent the material from spreading over the rooftop or becoming airborne.
  4. Submit material storage and disposal plan for review prior to job start.

**1.04 PATCHING, EXTENDING, AND MATCHING:**

- A. Patch and extend existing work using skilled mechanics who are capable of matching the existing quality of workmanship. The quality of patched or extended work shall not be less than that which exists.
- B. In areas where any portion of an existing finished surface is damaged, lifted, stained, or otherwise made or found to be imperfect, patch or replace the imperfect portion of the surface with matching material.
- C. Provide adequate support or substrate for patching of finishes.
- D. Quality:
  1. In the Sections of the product and execution of Specifications which follow these General Requirements, no concerted attempt has been made to describe each of the various existing products that must be used to patch, match, extend, or replace existing work. Obtain all such products in time to complete the Work on schedule. Such products shall be provided in quality which is in no way inferior to the existing products.
  2. The quality of the products that exist in the building, as apparent during pre-bid site visits, shall serve as the Specification requirement for strength, appearance, and other characteristics.

- E. Transitions:
1. Where new work abuts or finishes flush with existing work, make the transition as smooth and workmanlike as possible. Patched work shall match existing adjacent work in texture and appearance so as to make the patch or transition invisible to the eye at a distance of no closer than 3 feet (1m).
  2. Where masonry or other finished surface is cut in such a way that a smooth transition with new work is not possible, terminate the existing surface in a neat fashion along a straight line at a natural line of division and provide trim appropriate to the finished surface.
- F. Restore existing work that is damaged during construction to a condition equal to its condition at the time of the start of the Work, and to satisfaction of Owner.

**1.05 REPAIR:**

- A. Replace work damaged in the course of alterations, except at areas approved by Owner for repair.
- B. Where full removal of extensive amounts of almost-suitable work would be needed to replace damaged portions, then filling, straightening, and similar repair techniques, followed by finishing, will be permitted.
- C. If the repaired work is not brought up to the standard for new work, Owner will direct that it be cut out and replaced with new work.

**PART TWO - PRODUCTS**

Not Used.

**PART THREE - EXECUTION**

Not Used.

**END OF SECTION 01 12 00**

**SECTION 01 20 00**

**PROJECT MEETINGS**

**PART ONE - GENERAL**

**1.01 PROJECT MEETINGS:**

- A. Project meetings will be held at the site at a time to be designated by Owner.
- B. Representatives of Contractor shall meet with Owner or his appointed representative.

**1.02 PRE-CONSTRUCTION MEETING**

- A. Attendance:
  - 1. Owner.
  - 2. Consultant/Engineer.
  - 3. Contractor.
- B. Sign-in list for all attending including names, title, phone number, and company.
- C. Contract Review:
  - 1. Schedule of values and progress payment processing.
  - 2. Notice to proceed and start date.
  - 3. Project communications and problem resolution.
- D. Job Site Conditions and Requirements:
  - 1. Services (temporary):
    - a. Water.
    - b. Power (110, 220).
    - c. Sanitary facilities.
    - d. Parking areas.
  - 2. Site Access and Restrictions:
    - a. Set-up areas, material storage, and handling.
    - b. Protection of buildings, grounds, and building interior.
  - 3. Working Area and Preparation:
    - a. Review work flow and schedule.
- E. Technical Sections:
  - 1. Function of on-site inspector and other on site personnel.
  - 2. Material storage methods.
  - 3. System review.
  - 4. Manufacturer inspections:
- F. Safety and Security - Review Contractor responsibilities, and establish Owner monitoring procedures.
- G. Summary and Questions
- H. Issue record of meeting minutes to all attendees.

**1.03 PROJECT MEETING**

- A. Attendance:
  - 1. Owner.
  - 2. Consultant/Engineer.
  - 3. Contractor.
  - 4. Subcontractors.
- B. Sign-in list for all attending, including names, titles, phone numbers, and company name.
- C. Project Review:
  - 1. Problem resolution.
  - 2. Project communication.
  - 3. Review projected work flow and schedule against work completed to date.
  - 4. Progress payment processing.
- D. Job Site Conditions:
  - 1. Review set-up area, material storage, and handling.
  - 2. Review work to date against schedule.
  - 3. Review quality of work to-date.

**PART TWO - PRODUCTS**

Not Used.

**PART THREE - EXECUTION**

Not Used.

**END OF SECTION 01 20 00**

**SECTION 01 30 00**

**SUBMITTALS**

**PART ONE - GENERAL**

**1.01 SECTION INCLUDES:**

- A. Submittals required by Specification Sections and as listed in attached List of Submittals.

**1.02 REQUIRED SUBMITTALS:**

- A. Applicator's License Certificate: Copy of the roofing material manufacturer's agreement/contract indicating date application was approved and expiration date.
- B. Copy of the Contractor's executed insurance certificate.
- C. Material manufacturer's written approval/acceptance of specified roof system including roof system components, general installation requirements, performance criteria of proposed systems, and warranty to be issued for project.
- D. Copies of independent test reports indicating criteria of proposed roof system(s) meeting specified roof system performance.
- E. Shop drawings of details, if proposed different from project drawings.
- F. Manufacturer's product data sheets and Safety Data Sheets (SDS) on each material proposed for usage.
- G. Sample of warranty that is to be issued upon project completion.
- H. Detailed project schedule showing work phasing and proposed daily progress schedule.
- I. Written Safety Program.

**1.03 SHOP DRAWINGS:**

- A. Original drawings, prepared by Contractor, subcontractor, supplier, or distributor, which illustrate some portion of the Work, showing fabrication, layout, setting, or erection details, prepared by a qualified detailer.
- B. Prepare shop drawings for those details that are proposed different than the project drawings. Indicate on a roof plan, the proposed location of detail presented on shop drawing.
- C. Indicate joints, types, and locations of fasteners, shapes, sizes, expansion joints, special conditions, and installation procedures for each flashing condition. Note critical dimensions, gauge, and finish of sheet metal for each flashing condition.
- D. Submit shop drawings showing layout, joining, profiles, and anchorages of fabricated work, including counter flashings, metal edge flashings, and expansion joint systems.

**1.04 PRODUCT DATA:**

- A. Submit manufacturer's catalog sheets, brochures, diagrams, schedules, performance charts, illustrations, and other standard descriptive data for each material proposed for use in construction of roof assembly and related flashings and components.
  - 1. Clearly mark each copy to identify pertinent materials, products, or models.
  - 2. Show dimensions and clearances required.
  - 3. Show performance characteristics and capacities.

**1.05 SAMPLES:**

- A. Physical examples to illustrate materials, equipment, and workmanship; and to establish standards by which completed Work is judged, if requested.

**1.06 CONTRACTOR RESPONSIBILITIES:**

- A. Review shop drawings, product data, and samples prior to submission. Initial, sign, or stamp, certifying the Contractor's review of the submittal.
- B. Verify:
  - 1. Field measurements.
  - 2. Field construction criteria.
  - 3. Catalog numbers and similar data.
- C. Coordinate each submittal with requirements of Work and of Contract Documents.
- D. Contractor's responsibility for errors and omissions in submittals is not relieved by Consultant review of submittals.
- E. Contractor's responsibility for deviations in submittals from requirements of Contract Documents is not relieved by the Consultant's review of submittals, unless Consultant gives written acceptance of specific deviations.
- F. Begin no work which requires submittals until return of submittals with Consultant's stamp and initials or signature indicating review and indication to proceed as noted. Work performed prior to submission and approval of submittals may be subject for rejection.

**1.07 SUBMISSION REQUIREMENTS:**

- A. Schedule submissions to the Consultant after Contract award.
- B. Submit one electronic copy of submittals.
- C. Submit samples as requested.
- D. Accompany submittals with transmittal letter containing:
  - 1. Date.
  - 2. Project title and number.
  - 3. Contractor's name and address.
  - 4. The number of each submittal.
- E. Provide submittals bound together with a Cover and Table of Contents.

**1.08 RE-SUBMISSION REQUIREMENTS:**

- A. Product Data and Samples: Submit new data and samples as required for initial submittal.
- B. Shop Drawings:
  - 1. Revise initial drawings as required and re-submit as specified for initial submittal.
  - 2. Indicate on drawings any changes which have been made other than those requested by Owner.

**1.09 DISTRIBUTION OF SUBMITTALS AFTER REVIEW:**

- A. Consultant will retain approved submittals.
- B. Consultant will forward approved submittals to Owner.
- C. Consultant will return submittals to Contractor.

**1.10 LIST OF SUBMITTALS:**

**SECTION 01 30 00 - SUBMITTALS**

- Submittals - 1 electronic copy.

**SECTION 02 07 20 - MINOR DEMOLITION AND RENOVATION WORK**

- Product Data.

**SECTION 07 22 00 - ROOF AND DECK INSULATION**

- Product Data.
- Shop Drawings, where applicable.
- Samples, if requested.

**SECTION 07 52 50 - MODIFIED BITUMEN MEMBRANE ROOFING**

- Product Data.
- Roof system test reports.
- Shop Drawings, where applicable.
- Samples, if requested.

**SECTION 07 62 00 - SHEET METAL FLASHING AND TRIM**

- Product Data.
- Fabrication certifications.
- Shop Drawings, where applicable.
- Color Chart.

**PART TWO - PRODUCTS**

Not Used.

**PART THREE - EXECUTION**

Not Used.

**END OF SECTION 01 30 00**



**SECTION 01 40 00**

**QUALITY CONTROL**

**PART ONE - GENERAL**

**1.01 SECTION INCLUDES:**

- A. General Quality Control.
- B. Manufacturers' Field Services.

**1.02 QUALITY CONTROL, GENERAL:**

- A. Maintain quality control over suppliers, manufacturers, products, services, site conditions, and workmanship to produce work of specified quality.
- B. Contractor shall be approved by manufacturer to perform the work for the specified guarantee period. Contractor shall have completed previous projects utilizing same materials and provide same warranty as specified herein.
- C. Examine each phase of Work and have defective conditions corrected before starting subsequent operations which would cover, or are dependent upon, work in question.
- D. Where visual examination is not sufficient, such as in verifying slope of roof deck for proper drainage, use instruments with qualified operators to examine work.
- E. Perform roof removal and new roof material installation using full-time employees of the Contractor.

**1.03 WORKMANSHIP:**

- A. Comply with industry standards, except when more restrictive tolerances or specified requirements indicate more rigid standards or more precise workmanship.
- B. Utilize qualified personnel who have experience with the specified materials to produce workmanship of specified quality.
- C. Secure products in place with positive anchorage devices designed and sized to withstand stresses, vibration, and racking.
- D. Provide finishes to match accepted samples.

**1.04 MANUFACTURER'S FIELD SERVICES:**

- A. When specified in respective Specification Section, require manufacturer to provide qualified personnel to observe field conditions, conditions of surfaces and installation, quality of workmanship, and to make appropriate recommendations.

**PART TWO - PRODUCTS**

Not Used.

**PART THREE - EXECUTION**

Not Used.

**END OF SECTION 01 40 00**

**SECTION 01 43 00**

**MOCK-UPS**

**PART ONE - GENERAL**

**1.01 DESCRIPTION:**

- A. Preparation of mock-ups representing proposed finished sheet metal, flashings, and sheet metal assemblies for review and approval.

**1.02 QUALITY ASSURANCE:**

- A. Contractor to prepare mock-ups utilizing materials proposed for the finished product and to simulate the desired appearance of the finished product.
- B. Construct mock-ups at locations on the building for review.
- C. Mock-ups shall be of appropriate size to depict finishes and connections.
- D. Materials, finishes, thickness, attachments, dimensions, and profiles shall be as specified herein and as shown within the project.
- E. Owner or Owner's Representative reserves the right to require any modifications deemed necessary. No requests for extra costs will be entertained unless an upgrade of the original design is involved.
- F. Mock-ups shall constitute standard of acceptance for remaining work.

**1.03 SCHEDULE OF MOCK-UPS:**

- A. Typical rise wall flashing condition(s); size 3-feet minimum.
- B. Typical metal edge/fascia condition(s); size 3 feet minimum.
- C. Typical sheet metal coping condition; size 3 feet minimum; 2 color options.

**PART TWO - PRODUCTS**

Not Used.

**PART THREE - EXECUTION**

Not Used.

**END OF SECTION 01 43 00**

**SECTION 01 50 00**

**TEMPORARY FACILITIES AND CONTROLS**

**PART ONE - GENERAL**

**1.01 SANITARY FACILITIES:**

- A. Provide adequate temporary chemical toilets at time Work is commenced.
- B. Maintain facilities in compliance with applicable health laws and regulations. Keep clean and unobtrusive.
- C. Upon completion of Work, remove these facilities and all traces thereof.

**1.02 STORAGE OF MATERIALS:**

- A. Provide suitable non-combustible, watertight coverings for storage of materials subject to damage by weather. Covering shall be of sufficient size to hold materials required on site at one time. Pallets shall be raised at least 6-inches (150mm) above ground, on heavy joists or sleepers.
- B. If temporary storage sheds are used, locate storage areas where directed, maintain in good condition, and remove storage sheds when so directed. Locate storage areas of combustible construction a minimum of 30 feet (10m) from existing building.
- C. Store materials on site unless otherwise approved by Owner.
- D. Cover and protect materials subject to damage by weather, including during transit.
- E. Do not use building as storage facility.
- F. Provide additional storage at no cost to Owner in the event that additional storage area is required beyond that provided at project site.
- G. Stored materials shall be available for inspection by Owner at all times.
- H. Store flammable and volatile liquids in sealed containers located a minimum of 20 feet from existing buildings.
- I. Transport flammable or volatile liquids in, and use from, U.L. listed safety cans.
- J. Deliver material and equipment in manufacturer's original packaging with all tags and labels intact and legible. Handle and store material and equipment in such a manner as to avoid damage. Liquid products shall be delivered sealed, in original containers. Store roll goods in an upright position.
- K. Proper storage of materials is the sole responsibility of Contractor. Protect all materials susceptible to moisture including, but not limited to, all roll goods, insulation, cant strip, wood, and plywood in dry, above ground, watertight storage. Keep all labels intact and legible, clearly showing the product, manufacturer, and other pertinent information.
- L. Reject any materials becoming wet or damaged and remove from the jobsite immediately. Any insulation found to be improperly stored at the jobsite shall be considered wet at the discretion of Owner's Representative and removed from the jobsite.
- M. Maintain products liable to degrade as a result of being frozen above 40 degrees Fahrenheit (4 degrees Celsius) in heated storage.
- N. Random samples of all materials susceptible to moisture will be taken at various stages of the installation to ensure no significant variations in moisture.

- O. Distribute material, debris, and equipment over the roof deck to avoid damage to the structural deck. Place materials and equipment to be stored on the roof as nearly direct over structural members as can be determined. Secure equipment, material, and debris on the roof to prevent movement by wind or other elements. Contractor assumes full responsibility for loading on the structural deck or roofing materials during roof replacement operations. Owner's Representative reserves the right to reject any loadings deemed unacceptable.

**1.03 TEMPORARY WATER:**

- A. Make arrangements with Owner for water required for construction. Owner will pay for costs of water.
- B. Provide hoses for conveyance.

**1.04 TEMPORARY ELECTRICAL ENERGY:**

- A. Make arrangements with Owner for temporary electrical service for completion of the Work. Owner will pay energy charges for temporary power and lighting.
- B. Provide all necessary temporary wiring (in conduit if requested by Owner), extensions, and temporary lighting devices.

**1.05 TEMPORARY LADDERS, SCAFFOLDS, HOISTS:**

- A. Furnish and maintain temporary ramps, scaffolds, hoists, or chutes as required for proper execution of Work.
- B. Such apparatus, equipment, and construction shall meet requirements of applicable federal, state, and local safety and labor laws.

**1.06 GUARDRAILS, BARRICADES, AND TEMPORARY COVERINGS:**

- A. Provide barricades as required to protect natural resources, site improvements, existing property, adjacent property, and passers-by.
- B. Where pedestrian traffic is through or adjacent to work areas, provide necessary guardrails and barricades to protect pedestrians and to prevent pedestrian access to Work areas.
- C. Remove guardrails and barricades at completion of construction.
- D. Provide suitable temporary watertight coverings over windows and roof openings as required to protect interior equipment from inclement weather.
- E. Provide suitable protection for stairs, elevator, and/or walls and floors in areas used for contractor roof access.

**1.07 PROTECTION:**

- A. Maintain bench marks, monuments, and other reference points. If disturbed or destroyed, replace as directed.
- B. Protect existing adjacent streets, sidewalks, curbs, buildings, and property including trees, lawns, and plants.
- C. Refer to Section 01 12 00 - Alterations Project Procedures, for protection requirements of existing building.

**1.08 TEMPORARY FIRE PROTECTION:**

- A. During construction, Contractor and his subcontractors and sub-subcontractors and their agents and employees shall comply with fire safety practices as outlined in NFPA Pamphlet 241 and local fire protection codes, and in addition shall:
  - 1. Provide following stored pressure extinguishers during entire construction period:
    - a. One U.L. rating 4A-60B:C dry chemical fire extinguisher.
    - b. One U.L. rating 2A 2-1/2 gallon water fire extinguisher.
    - c. One U.L. rating 10B:C carbon dioxide fire extinguisher with horn and hose assembly.
  - 2. Provide fire extinguishers together in each of following areas:
    - a. Each 3000 square feet of work area or fraction thereof.
  - 3. Contractor's superintendent or other assistant superintendents shall be appointed as project fire warden for entire construction period.
  - 4. Train workmen in proper use of each type fire extinguisher.
  - 5. Post telephone number of fire department, specific information regarding location of on-site fire fighting equipment, and procedures to be followed in event of fire.
  - 6. Maintain free access at all times to fire extinguisher equipment, street fire hydrants, and outside connections for standpipe hose systems.
  - 7. Maintain all exit facilities and access thereto, free of material and other obstructions.

**1.09 EMPLOYEE CONTROL:**

- A. Do not allow construction employees to enter Owner-occupied areas. Maintain construction traffic in designated access routes.

**1.10 PARKING FACILITIES:**

- A. Parking area for a designated number of construction personnel vehicles will be made available at the site by Owner.

**1.11 CLEANING DURING CONSTRUCTION:**

- A. Oversee cleaning and ensure that building and grounds are maintained free from accumulations of waste materials and rubbish.
- B. Sprinkle dusty debris with very fine water mist to control accumulation of dust. Do not use water in quantity so as to puddle.
- C. At not less than every day during progress of work, clean up work areas and access areas and dispose of waste materials, rubbish, and debris.
- D. At Contractor's option, on-site dump containers may be used for collection of waste materials, rubbish, and debris. Locate containers a minimum of 30 feet (10m) away from building entrances at a location acceptable to Owner. If used, remove containers when filled.
- E. Do not allow waste materials, rubbish, and debris to accumulate and become an unsightly or dangerous condition.
- F. Remove waste materials, rubbish, and debris from site and legally dispose of at public or private dumping areas off Owner's property.

- G. Keep streets and access to site free of rubbish and debris.
- H. Lower waste materials in a controlled manner with as few handlings as possible. Do not drop or throw materials from heights.

**1.12 LEAK (WATER) DAMAGE CONTROL:**

- A. In the event of rain during roof replacement construction operations, immediately inspect interior of building for leaks.
- B. Coordinate with Owner for access to building.
- C. Continue to inspect building on a regular basis until rain ceases.
- D. If leaks are discovered during rains, immediately cover and protect equipment with fire retardant sheeting in the area of the leak. Immediately notify Owner of leak condition.
- E. Take necessary precautions to protect the roof from damage. Repair all new areas of damage caused by the negligence of Contractor, at Contractor's expense. Owner's On-site Representative shall determine damage caused by Contractor negligence.

**1.13 PERMITS:**

- A. Obtain and pay for all required local and state permits, licenses, and registrations. Work may be subject to ordinances, laws, codes, and regulations.
- B. Prior to bidding, notify Owner and Consultant of any violation, omission, or questions of compliance. Required corrections to Specifications will be made via Addenda prior to receipt of Bids.
- C. Be responsible for full compliance and bear cost of additional work not specified that may be required by authorities having jurisdiction.

**1.14 REGULATORY REQUIREMENTS:**

- A. International Building Code (IBC), latest edition; as amended by the governing body.
- B. Occupation Safety and Health Administration (OSHA) requirements, as applicable.
- C. United States Environmental Protection Agency (EPA) requirements, as applicable.
- D. Adhere to all limitations, cautions, and regulatory standards referenced by the manufacturer of each material provided.

**PART TWO - PRODUCTS**

Not Used.

**PART THREE - EXECUTION**

Not Used.

**END OF SECTION 01 50 00**

**SECTION 01 60 00**

**MATERIAL AND EQUIPMENT**

**PART ONE - GENERAL**

**1.01 SECTION INCLUDES:**

- A. Material and Equipment Incorporated Into Work:
  - 1. Conform to applicable specifications and standards.
  - 2. Comply with size, make, type, and quality specified, or as specifically approved in writing by Owner.
  - 3. Manufactured and Fabricated Products:
    - a. Design, fabricate and assemble in accordance with recognized industry standards.
    - b. Manufacture like parts of duplicate units to standard sizes and gauges, to be interchangeable.
    - c. Two or more items of same kind shall be identical, by same manufacturer.
    - d. Products suitable for service conditions.
    - e. Adhere to equipment capacities, sizes, and dimensions shown or specified unless variations are specifically approved in writing.
- B. Do not use material or equipment for purposes other than that for which it is designed or is specified.

**1.02 REUSE OF EXISTING MATERIAL:**

- A. Except as specifically indicated or specified, materials and equipment removed from existing structure shall not be used in completed Work.
- B. For material and equipment specifically indicated or specified to be reused in Work:
  - 1. Use special care in removal, handling, storage, and reinstallation to assure proper function in completed Work.
  - 2. Arrange for transportation, storage, and handling of products which require off-site storage, restoration, or renovation. Pay costs for such work.

**1.03 MANUFACTURER'S INSTRUCTIONS:**

- A. When Contract Documents require that installation of work shall comply with manufacturer's printed instructions, obtain and distribute copies of such instructions to parties involved in installation, including two copies to Consultant.
  - 1. Maintain one set of complete instructions at jobsite during installation and until completion.
  - 2. Submit two copies to Consultant with appropriate Product Data submittal.
  - 3. Consultant will forward one copy to Owner.
- B. Handle, install, connect, clean, condition, and adjust products in strict accordance with such instructions and in conformity with specified requirements.
  - 1. Should job conditions or specified requirements conflict with manufacturer's instructions, consult with Consultant for further instructions.
  - 2. Do not proceed with work without clear instructions.



- C. Perform Work in accordance with manufacturer's instructions. Do not omit preparatory steps or installation procedures unless specifically modified or exempted by Contract Documents.

**1.04 TRANSPORTATION AND HANDLING:**

- A. Arrange deliveries of products in accordance with construction schedules. Coordinate to avoid conflict with work and conditions at site.
1. Deliver products in undamaged condition, in manufacturer's original containers or packaging, with identifying labels intact and legible.
  2. Immediately on delivery, inspect shipments to assure compliance with requirements of Contract Documents and approved submittals, and that products are properly protected and undamaged.
- B. Provide equipment and personnel to handle products by methods to prevent soiling or damage to products or packaging.

**1.05 SUBSTITUTIONS AND PRODUCT OPTIONS:**

- A. Contractor's Options:
1. For products specified only by reference standard, select any product meeting that standard, by any manufacturer.
  2. For products specified by naming several products or manufacturers, select any product and manufacturer named.
  3. Products specified by naming only one product and manufacturer are to establish a quality standard. For products other than the named product, submit request for substitution as specified below.
- B. Substitutions:
1. During Bidding, Consultant will consider written requests from Bidders and manufacturers for substitutions of products in place of those specified. Such requests must be received at least two days prior to Bid Date. Requests received after that time will not be considered. Approval of proposed substitutions will be set forth in an Addendum or letter of approval. Requests for substitutions shall include data listed below.
  2. Submit two copies of request for each substitution, supported with complete data, drawings, and appropriate samples substantiating compliance of proposed substitution with Contract Documents, including:
    - a. Product description, performance and test data, and applicable reference standards.
    - b. Name and address of similar projects on which product was used and date of installation.
    - c. Itemized comparison of qualities of proposed substitution with that specified.
    - d. Changes required in other elements of Work because of substitution.
    - e. Affect on construction schedule.
    - f. Availability of maintenance service and source of replacement materials.

- C. Contractor's Representation: Request for substitution constitutes a representation that Contractor:
  - 1. Has investigated proposed product and determined that it is equal to or superior in all respects to that specified.
  - 2. Will provide same warranties for substitution as for product specified.
  - 3. Will coordinate installation of accepted substitution into Work and make such other changes as may be required for Work to be complete in all respects.
  - 4. Waives all claims for additional costs, under his responsibility, related to substitution which subsequently becomes apparent.
- D. Substitutions will be not be considered if:
  - 1. They are indicated or implied on Shop Drawings or Product Data submittals without formal request submitted in accordance with this Section.
  - 2. They are submitted after time limit specified above.
  - 3. Acceptance will require substantial revision of Contract Documents.
- E. If substitution is not approved or accepted, Contractor shall furnish specified product.

**PART TWO - PRODUCTS**

Not Used.

**PART THREE - EXECUTION**

Not Used.

**END OF SECTION 01 60 00**

**SUBSTITUTION REQUEST FORM**

---

TO:  
Mr. \_\_\_\_\_  
Owner

PROJECT NO.: **11204.15**  
FROM(CONTRACTOR/BIDDER):

Attn:

---

CONTRACTOR (BIDDER) HEREBY REQUESTS ACCEPTANCE OF THE FOLLOWING PRODUCT OR SYSTEM AS A SUBSTITUTION IN ACCORDANCE WITH PROVISIONS OF DIVISION ONE OF THE SPECIFICATIONS:

**1. SPECIFIED PRODUCT OR SYSTEM:**

Substitution request for (Generic Description):  
Specification Section No. \_\_\_\_\_ Article(s) \_\_\_\_\_ Para.(s) \_\_\_\_\_

**2. SUPPORTING DATA:**

Product data for proposed substitution is attached (description of product, reference standards, performance and test data).

Sample is attached       Sample will be sent if requested

**3. QUALITY COMPARISON:**

	<u>SPECIFIED PRODUCT</u>	<u>SUBSTITUTION</u>
Name, Brand:	_____	_____
Catalog No.:	_____	_____
Manufacturer:	_____	_____
Vendor:	_____	_____
Significant Variations:	_____	_____
	_____	_____

Maintenance Service Available:  Yes  No

Spare Parts Source:

**4. PREVIOUS INSTALLATIONS:**

Identification of similar projects on which proposed substitution was used:

Project: \_\_\_\_\_ Architect: \_\_\_\_\_  
Address: \_\_\_\_\_ Owner: \_\_\_\_\_  
Date Installed: \_\_\_\_\_

**5. REASON FOR NOT GIVING PRIORITY TO SPECIFIED ITEMS:**

\_\_\_\_\_  
\_\_\_\_\_

**THE UNIVERSITY OF TEXAS HEALTH SCIENCE CENTER  
SCHOOL OF NURSING  
HOUSTON, TEXAS**

---

**6. EFFECT OF SUBSTITUTION:**

Proposed substitution affects other parts of Work:  No  Yes  
(If yes, explain)

---

---

Substitution changes contract time:  No  Yes  
Add/Deduct \_\_\_\_\_ days

Substitution requires dimensional revision or redesign of structure or M & E Work:  
 No  Yes (If yes, attach complete data.)

Saving or credit to Owner, if any, for accepting substitution: \$\_\_\_\_\_  
Extra cost to Owner, if any, for accepting substitution: \$\_\_\_\_\_.

**7. CONTRACTOR'S (BIDDER'S) STATEMENT OF CONFORMANCE OF PROPOSED SUBSTITUTION TO CONTRACT REQUIREMENTS:**

I/we have investigated the proposed substitution. I/we:

- believe that it is equal or superior in all respects to specified product, except as stated above;
- will provide the same warranty as specified for specified product;
- will pay redesign and special inspection costs caused by the use of this product;
- will pay additional costs to other contractors caused by the substitution;
- will coordinate the incorporation of the proposed substitution in the Work;
- will modify other parts of the Work, as may be needed, to make all parts of the Work complete and functioning;
- waive future claims for added cost to Contract caused by the substitution.

Contractor (Bidder): \_\_\_\_\_ Date: \_\_\_\_\_

By: \_\_\_\_\_

**Answer all questions and complete all blanks - use "NA" if not applicable.**

**CONSULTANT'S REVIEW AND ACTION**

Resubmit Substitution Request Form:  
Provide more information in the following categories: \_\_\_\_\_

Sign Contractor's (Bidder's) Statement of Conformance.

Substitution is accepted.

**THE UNIVERSITY OF TEXAS HEALTH SCIENCE CENTER  
SCHOOL OF NURSING  
HOUSTON, TEXAS**

---

Substitution is accepted with the following comments: \_\_\_\_\_  
\_\_\_\_\_  
\_\_\_\_\_

Substitution is not accepted.

Substitution Request Form received too late.

\_\_\_\_\_  
Consultant

\_\_\_\_\_  
Title

\_\_\_\_\_  
Date

\_\_\_\_\_  
Owner

**SECTION 01 70 00**

**CONTRACT CLOSEOUT**

**PART ONE - GENERAL**

**1.01 GENERAL:**

- A. Comply with requirements stated in Conditions of the Contract and in Specifications for administrative procedures in closing out the Work.

**1.02 SUBSTANTIAL COMPLETION:**

- A. Contractor: Shall notify Owner's Representative that Project is substantially complete and schedule time for inspection.
- B. Owner's Representative will make an inspection after notification.
- C. Should Owner's Representative consider Work not complete:
  - 1. He will immediately notify Contractor, in writing, stating reasons.
  - 2. Contractor shall complete Work and send second written notice to Owner's Representative certifying Project is substantially complete.
  - 3. Owner's Representative will reinspect Work.

**1.03 FINAL INSPECTION:**

- A. Contractor shall submit written certification that:
  - 1. Contract Documents have been reviewed.
  - 2. Project has been inspected for compliance with Contract Documents.
  - 3. Work has been completed in accordance with Contract Documents.
  - 4. Equipment and systems have been tested in presence of Owner's Representative and are operational.
  - 5. Project is complete and ready for final inspection.
- B. Owner's Representative will make final inspection after notification from Contractor.
- C. Should Owner's Representative consider Work complete in accordance with requirements of Contract Documents, he will request Contractor to make Project Closeout submittals.
- D. Should Owner's Representative consider Work not complete:
  - 1. He will notify Contractor in writing, issuing inspection list to Contractor with noted items requiring further consideration.
  - 2. Contractor shall take immediate steps to remedy the stated deficiencies and submit initialed inspection list to Consultant certifying Work is complete.
  - 3. Owner's Representative will reinspect Work.

**1.04 CLOSE-OUT SUBMITTALS:**

- A. Evidence of compliance with requirements of governing authorities.
- B. Warranties and Bonds: Refer to requirements of this Section.
- C. Evidence of Payment and Release of Liens: Refer to requirements of General and Supplementary Conditions.

**1.05 WARRANTY/GUARANTEE:**

- A. Submit original and duplicate copies of both Contractor's Warranty and Manufacturer's Guarantee to Owner's Representative for review. After review, Owner's Representative will forward Warranty and Guarantee to Owner. Consultant shall approve final pay application (retainage) upon receipt of both Contractor's Warranty and Manufacturer's Guarantee.

**1.06 EVIDENCE OF PAYMENTS AND RELEASE OF LIENS:**

- A. Final Release and Waiver of Liens:
  - 1. Contractor's Waiver of Liens.
  - 2. Separate waivers of liens for subcontractors, suppliers, and others with lien rights against property of Owner, together with complete list of those parties.
- B. All submittals shall be notarized and sealed before delivery to Owner's Representative.

**1.07 FINAL APPLICATION FOR PAYMENT:**

- A. Submit final application in accordance with requirements of General Conditions.
- B. Owner's Representative shall review all data supplied for conformance with Contract Documents. When approved, Owner will accept the Work, release Contractor (except as to conditions of the Performance Bond, any legal rights of Owner, required guarantees, and correction of Faulty Work after final Payment), and make final payment to Contractor.
- C. Final payment will not be approved or released until receipt of proper close-out documents.

**PART TWO - PRODUCTS**

Not Used.

**PART THREE - EXECUTION**

Not Used.

**END OF SECTION 01 70 00**

**SECTION 01 71 00**

**CLEANING**

**PART ONE - GENERAL**

**1.01 GENERAL:**

- A. Maintain premises free from accumulations of waste, debris, and rubbish caused by construction operations.
- B. At completion of Work, remove waste materials, rubbish, tools, equipment, machinery, and surplus materials. Clean all sight-exposed surfaces. Leave project clean and ready for occupancy.

**1.02 REQUIREMENTS OF REGULATORY AGENCIES:**

- A. Codes and Standards: Applicable federal, state, and local codes and regulations relative to environmental safety regulations.
- B. Hazards Controls: Store volatile waste in covered metal containers and remove from premises daily. Prevent accumulation of wastes which create hazardous conditions.
- C. Pollution Control: Conduct clean-up and disposal operations to comply with local ordinances and anti-pollution laws.
  - 1. Burning or burying of rubbish and waste materials on the project site is prohibited.
  - 2. Disposal of volatile fluid wastes (such as mineral spirits, oil, or paint thinner) in storm or sanitary sewer systems or into streams or waterways is prohibited.

**PART TWO - PRODUCTS**

**2.01 CLEANING MATERIALS:**

- A. Use only cleaning materials recommended by manufacturer of surface to be cleaned.
- B. Use cleaning materials only on surfaces recommended by cleaning material manufacturer.

**PART THREE - EXECUTION**

**3.01 DURING CONSTRUCTION:**

- A. Keep work area and all occupied property in neat and orderly condition at all times. Oversee cleaning and ensure that building and grounds are maintained free from accumulations of waste materials and rubbish. Sprinkle dusty debris with very fine water mist to control accumulation of dust. Do not use water in quantity so as to puddle. Do not allow waste and other materials such as rubbish, debris, wrappers, etc., to accumulate and become unsightly or hazardous. Promptly remove equipment and excess materials as they become no longer needed for the progress of the work. At not less than every day during progress of work, clean up work and access areas and dispose of waste materials, rubbish, and debris.



- B. Legally dispose of waste materials, rubbish, and debris at public or private dumping areas off Owner's property. At the completion of work, restore work area to its original condition. Lower waste materials in a controlled manner with as few handlings as possible; do not drop or throw materials from heights. Keep street and access to site free of rubbish and debris.
- C. Contractor shall be responsible for damage to or destruction of property of any sort resulting from the work or caused by defective work, or the use of unsatisfactory materials or workmanship.
- D. Contractor shall be responsible for the preservation of all private property, trees, fences, etc., along the adjacent street, right-of-way, etc., and shall use every precaution necessary to prevent damage or injury thereto. Use suitable precautions to prevent damage to pipes, conduits, and other structures.
- E. If damage to any structures, utilities, or other improvement occurs by reason of Contractor's operations even though special precautions have been employed, Contractor shall be entirely responsible for such damage and shall make all repairs as required to the satisfaction of Owner.
- F. Do not injure, destroy, or trim landscaping without authorization by Owner. Landscaping damage will be replaced by Contractor with new stock or with other stock satisfactory to Owner at the expense of Contractor.

**3.02 FINAL CLEANING:**

- A. Employ skilled workmen for final cleaning.
- B. Remove grease, mastics, adhesives, dust, dirt, stains, labels, fingerprints, and other foreign materials from sight-exposed interior and exterior surfaces.
- C. Repair, patch, and touch-up marred surfaces to match adjacent finishes.
- D. Broom clean paved surfaces; rake clean other surfaces of grounds.
- E. Clean areas impacted by work activities.
- F. Prior to final completion or Owner occupancy, conduct an inspection of sight-exposed interior and exterior surfaces and all work areas to verify that entire Work area is clean.

**END OF SECTION 01 71 00**

**SECTION 02 07 20**

**MINOR DEMOLITION AND RENOVATION WORK**

**PART ONE - GENERAL**

**1.01 SECTION INCLUDES:**

- A. Removing existing roofing, insulation, flashing, and sheet metal.
- B. Modifying existing roof penetrations, equipment supports or curbs, pitch pans, reglets, piping, and electrical service to provide proper flashing height and flashing detail.
- C. Installing new wood nailers at designated locations.
- D. Removing abandoned penetrations and repairing openings in deck.
- E. Repairing deck as required.
- F. Other miscellaneous and incidental work required to install complete roofing system as specified and to obtain specified manufacturer's warranty.

**1.02 RELATED SECTIONS:**

- A. 07 22 00 - Roof and Deck Insulation.
- B. 07 52 50 - Modified Bitumen Membrane Roofing.
- C. 07 62 00 - Sheet Metal Flashing and Trim.

**1.03 REFERENCES:**

- A. American Society for Testing and Materials (ASTM).
- B. Corps of Engineers (CRD).

**1.04 PROJECT CONDITIONS:**

- A. Environmental Requirements:
  - 1. Do not remove existing roofing and flashing in inclement weather or when rain is predicted with 30 percent possibility.
  - 2. When ambient temperature is below 60 degrees Fahrenheit (15 degrees Celsius), expose only enough cement and adhesive required within four hour period.
  - 3. Do not expose membrane and accessories to constant temperature in excess of 180 degrees Fahrenheit (82 degrees Celsius).
- B. Emergency Equipment: Maintain on-site materials necessary to apply emergency temporary seal in event of sudden storms or inclement weather.
- C. Smoking is prohibited on roof areas, in existing building, and all of Owner's property.

**1.05 SEQUENCING AND SCHEDULING:**

- A. Sequence minor demolition and renovation with sequence of new work to maintain facility in dry, watertight condition.
- B. Coordinate roof work so that no more existing items are removed in one day than can be replaced with new roofing work in same day.
- C. Coordinate work with Owner's operational requirements.

- D. Coordinate demolition work and removal with roofing work to maintain facility in dry, watertight condition.

**1.06 WARRANTY:**

- A. Provide Contractor's warranty covering defects in installed materials and workmanship for period of two years from date of final acceptance.

**PART TWO - PRODUCTS**

**2.01 MATERIALS:**

- A. Treatment for Wood Members: Pressure preservative treated in accordance with AWPA C2, C9 standards, Ground Contact using ACQ, MCQ, or other similar treatment at 0.20 pounds per cubic foot wood above ground.
- B. Lumber for Nailers and Blocking: Standard Grade Fir or No. 2 Southern Yellow Pine bearing UL label; size shall be appropriate for application, minimum 2-inch (50mm) (nominal) thickness, kiln dried after treatment.
- C. Plywood: Minimum 5/8-inch APA exterior grade sheathing, EXP 1 or "CDX", bearing APA trademark.
- D. Gypsum Sheathing: 5/8-inch thick moisture resistant gypsum core with fiberglass facer and primed top surface such as "Dens-Deck Prime" by Georgia Pacific.
- E. Fasteners:
  - 1. Wood Substrate:
    - a. Securement of metal flanged items such as flashing pans, metal edge/fascia, cleats, etc., shall be nails, No. 11 gauge, double hot-dipped galvanized, ASTM A153, steel or stainless steel wire with 3/8-inch (9mm) diameter head and ring shank fasteners for anchoring flanges of sheet metal fabrications shall be of sufficient length to achieve a minimum 1-1/4-inch embedment into solid wood substrate such as "R-103-A Stormguard Asphalt and Fiberglass Shingle Nail" by Maze Nails (800/435-5949).
    - b. Securement of wood to wood shall be nails, No. 11 gauge, double hot-dipped galvanized steel or stainless steel wire nail with ring shank and 9/32-inch (7mm) diameter head such as "Stormguard PTL Anchor-Down Nail" by Maze Nails (800/435-5949); 10d or length required to provide 1-inch (25mm) penetration minimum into substrate.
    - c. Securement of exposed items to wood substrate shall be No. 14 stainless steel screw with stainless steel washer and integral rubber seal; length required to provide 1-inch (25mm) penetration minimum into substrate.
    - d. Fasteners for securing roofing materials to wood substrate shall be a hardened steel nail with a 1-inch (25mm) diameter round head and ring shank; length to provide 1-inch (25mm) penetration into substrate, as manufactured by Simplex Nail Co.
    - e. Fasteners for securing steel to wood substrate shall be No. 10 stainless steel wood screw with stainless steel washer and integral rubber seal, length to achieve 1-inch embedment into wood.

- f. Fasteners for securing wood nailer to wood nailer in vertical position shall be 20 gauge galvanized steel plate, 2-inches wide by 4-inches long such as "MP 24 Mending Plate" by Simpson Strong-Tie Co., Inc. and "A34 Framing Anchor" by Simpson Strong-Tie Co., Inc. for corner connections.
2. Concrete Substrate:
    - a. Fasteners for securing sheet metal items such as surface-mounted counterflashings, termination/compression bars, etc., to concrete substrate shall be a pre-assembled drive anchor with a stainless steel drive screw, a lead/zinc alloy expansion anchor body (1/4-inch (6mm) diameter, 1-1/2-inch [38mm] length) and a stainless steel washer with integral rubber seal (1-1/8-inch diameter) such as "Zamac Hammer-Screw" as manufactured by Powers Fasteners, Inc.
    - b. Fasteners for securing wood blocking to concrete substrate at roof perimeters shall be sleeved stud expansion bolt, 1/2-inch (13mm) diameter (minimum), with 3/4-inch diameter steel washer such as "Kwik Bolt II" by Hilti, "Tru Bolt Wedge" by ITW Ramset, or "Lok/Bolt" by Powers Fasteners, Inc. Fasteners for securing wood blocking to concrete substrate for miscellaneous applications shall be 1/4-inch diameter, 2-3/4-inch long coated screw with hex head such as "Tapcon" by ITW Buildex.
  3. Masonry Substrate:
    - a. Fasteners for securing wood to solid masonry at roof perimeters shall be galvanized steel expansion anchor, 3/8-inch (9mm) diameter (minimum), with 3/4-inch diameter steel washer such as "Countersunk Kwik Bolt II" by Hilti. Fasteners for securing wood to solid masonry for miscellaneous applications shall be 1/4-inch diameter, 2-3/4-inch long coated screw with hex head such as "Tapcon" by ITW Buildex.
    - b. Fasteners for securing wood to hollow base masonry shall be 3/8-inch (9mm) diameter (minimum), threaded rod, with 3/4-inch diameter washer, nut, and screen tube such as "HIT C-20 Adhesive Anchor" by Hilti.
    - c. Fasteners for securing sheet metal items to concrete substrate shall be a pre-assembled drive anchor with a stainless steel drive screw, a lead/zinc alloy expansion anchor body (1/4-inch (6mm) diameter, 1-1/2-inch [38mm] length) and a stainless steel washer with integral rubber seal (1-1/8-inch diameter) such as "Zamac Hammer-Screw" as manufactured by Powers Fasteners, Inc.
  4. Steel Substrate:
    - a. Fasteners for securing plywood to steel substrate shall be self-drilling, 1-1/2-inch long coated No. 10 screw with wafer head such as "Traxx Wood to Metal Fastener" by ITW Buildex. Fasteners for securing wood nailers/blocking to steel substrate shall be self-drilling coated heavy duty screw, 1/4-inch (6mm) diameter (minimum), with 5/8-inch (16mm) diameter washer such as "No. 14 Heavy Duty Screw" by OMG Roof Products.
    - b. Fasteners for securing steel to steel substrate shall be self-tapping No. 14, 1-1/2-inch long stainless steel screw with stainless steel washer and bonded integral rubber seal.

5. Plywood Clip: 20 gauge galvanized steel H-clip such as "PSCL Panel Sheathing Clip" by Simpson Strong-Tie Co., Inc. (800/999-5099).
6. Receiver in Reglet: Soft, malleable lead sheet, size and shape to fit in joint and maintain compression against receiver.
- F. Rust Inhibitive Primer: 100 percent acrylic resin primer such as "Metalclad Interior-Exterior Acrylic Latex Flat Primer & Finish #41702", Devoe & Raynolds Co.
- G. Piping/Conduit Supports: Pre-manufactured assembly with molded plastic/rubber base, 10-inches by 16-inches (250mm by 400mm); 1/2-inch (13mm) threaded rods and accessory bar, "Type PP-10 with Strut" for conduit/condensate or "Type PP-10 with Roller" for steel/gas piping as manufactured by PHP Systems/Design, Houston, Texas (800/797-6585). Pre-manufactured assembly with steel base and molded rubber roller such as Models 48-R-AH and 24-R-AH by Miro Industries, Inc. (800/768-9678).
- H. Non-shrink Grout: Quick-setting grout formula meeting Corps of Engineers specification CRD-C-621, Type D and ASTM C-1107, Grade C, such as "Five Star Instant Grout" by Five Star Products, Inc., "Sika Grout 212" by Sika Corp., or approved equal.
- I. Concrete Deck Repair Material: Multi-component, polymer modified Portland cement mortar, trowel-grade such as "SikaTop 122 Plus" by Sika, or approved equal.
- J. Paint for Roof-top Items: Lusterless (Flat) Acrylic Finish: Two coats over filler coat or primer coat such as Acrylic Primer of "ProIndustrial Acrylic Primer" by Sherwin Williams and Finish Coat of "ProIndustrial Acrylic Paint" by Sherwin Williams or approved equal.

### **PART THREE - EXECUTION**

#### **3.01 EXAMINATION:**

- A. Examine existing building and existing roofing to determine existing physical conditions that affect removal of existing roofing and installation of new roofing.
- B. Verify that required barricades and other protective measures are in place.

#### **3.02 PREPARATION:**

- A. Take measures to maintain watertight conditions during term of Contract.
- B. Install interior protection and dust partitions where deck penetrations shall be removed or replaced.
- C. Protect adjacent surfaces.
- D. Roof Drains:
  1. Examine existing drain lines for debris or blockage.
  2. Clean drains and drain lines, removing debris, excessive bitumen, or aggregate. Flush with water to ensure that drains flow freely.
  3. Cap drains with drain plugs during daily operations.
  4. Remove plugs after daily clean-up and prior to onset of rainfall.

**3.03 MINOR DEMOLITION OPERATIONS:**

- A. Execute demolition in careful and orderly manner with least possible disturbance or damage to adjoining surfaces and structure.
- B. Avoid excessive vibrations in demolition procedures that would be transmitted through existing structure and finish materials.
- C. Roof Removal:
  - 1. Remove existing roofing, insulation, and flashings; abandoned and obsolete equipment; pitch pans, vents, curbs, and other such items; and sheet metal down to roof deck.
  - 2. Trim existing counterflashing as required for installation of new materials.
  - 3. Do not stockpile debris on roof surface. Promptly dispose of obsolete equipment and debris at authorized disposal site each day. Use chutes to transfer debris from roof surface to dumpsters.
  - 4. Provide protective method, such as plywood set on minimum 1-inch (25mm) EPS insulation, when hauling debris over existing roof membrane.

**3.04 MINOR RENOVATION WORK:**

- A. Prepare substrates in accordance with roofing manufacturer's recommendations.
- B. Decking:
  - 1. Install new decking of like type, weight, gauge, and dimensions to provide suitable substrate in areas of deteriorated deck or where penetrations through deck are removed.
  - 2. Metal Decking:
    - a. Cover holes or openings 12-inches (300mm) in diameter or smaller with a plate of 18 gauge sheet metal. Extend plate minimum 4-inches (100mm) beyond edge of hole and onto adjacent unaffected rib. Mechanically fasten new decking or plate with screws spaced 6-inches (150mm) on-center.
    - b. Repair holes or openings greater than 12-inches (300mm) in diameter with new deck material. Extend new decking 18-inches (300mm) minimum past nearest bar joist or support member. Mechanically fasten new decking or plate with screws spaced 6-inches (150mm) on-center.
    - c. Remove loose rust, bitumen, or other foreign material from existing deck that would prohibit proper installation of new materials.
    - d. Remove rust by wire brushing or other appropriate method. Apply rust inhibitor over prepared areas of metal deck. Include allowance to paint entire surface of metal roof deck.
    - e. Secure existing metal roof deck to existing steel framing with self-drilling #14 screws spaced 12-inches on-center.
  - 3. Concrete Decking:
    - a. Perform repairs to concrete deck in accordance with patching material manufacturer's recommendations.
    - b. Apply rust inhibitor to exposed rebar.
    - c. Remove loose and defective concrete.
    - d. Patch spalled areas and exposed rebar areas with non-shrink grout.
    - e. Trowel smooth the properly placed grout.

- f. Seal cracks and/or joints in concrete deck with modified bitumen membrane prior to installation of new roof materials.
  - g. Cover holes or openings 12-inches (300mm) in diameter or smaller with a plate of 18 gauge sheet metal. Extend plate minimum 4-inches (100mm) beyond edge of hole and onto adjacent unaffected rib.
  - h. Holes Larger Than 12-Inches: Holes or openings greater than 12-inches by 12-inches (300mm by 300mm), frame opening with 2X wood nailers with intermediate spanning members spaced 16-inches (400mm) on-center. Install plywood flush with top of deck. Install layer of gypsum sheathing on bottom side of nailers. Provide finish on bottom side of opening to match adjacent finish in exposed areas.
- C. Nailers:
- 1. Replace damaged or deteriorated wood nailers and curbs with new nailers and curbs as required.
  - 2. Install wood nailers to match height of new insulation board.
  - 3. Secure 2X base nailer into structure and/or substrate for anchorage of cleats and/or fascias of sheet metal fabrications, width as necessary to extend beyond horizontal flange of sheet metal fabrication.
  - 4. Clean and prepare existing surfaces to receive wood nailers and curbs.
  - 5. Install 2 X 6 wood nailer, minimum, as base nailer at perimeters or tops of parapet walls. Nailers shall match width of wall and provide minimum 1-inch per foot slope toward roof.
  - 6. Install wood nailers and curbs continuously with 1/4-inch (6mm) gap between each section. Set level and true. Pre-drill nailers prior to attachment. Countersink fastener in base nailer so that washer and head of fastener or nut are recessed below top of nailer.
  - 7. Securely fasten to structure with appropriate fasteners to resist minimum 175 pounds per linear foot (780N per 300mm) force in any direction and spaced 12-inches on-center. Use of powder-actuated fasteners is prohibited. Place a fastener within 3-inches (75mm) of each end of each section of wood blocking.
  - 8. Secure nailers to concrete deck with appropriate fasteners spaced 24-inches (600mm) on-center. Secure nailer with a minimum of two fasteners per nailer.
  - 9. Stagger joints in subsequent layers of nailers from joints in underlying layer of nailers a minimum of 12-inches (300mm).
  - 10. Install nailers so that ends and sides of adjoining nailers are aligned to form right angles (nominal) at corners.
  - 11. Weave ends of subsequent layers of nailers at corners so that ends of nailers do not align.
  - 12. Secure nailers to metal deck with screws spaced 12-inches (300mm) on-center, 6-inches (150mm) on-center, 10 foot (3m) from each corner.
  - 13. Secure nailers to wood substrate using nails 24-inches (600mm) on-center, staggered. Install nails on an angle.
  - 14. Secure nailers with self-tapping steel fastener to structural steel with self-drilling screw or through-bolt spaced 12-inches on-center.

15. If attaching wood nailer to concrete masonry block, install stainless steel threaded rod spaced 12-inches (300mm) on-center in fully grouted cell/core of CMU.
  16. Reduce fastener spacing 50 percent at a distance of 10 feet (3m) from each corner.
  17. Secure new nailer to existing nailer or curb when increasing curb height utilizing appropriate fasteners, gusset plates, and framing anchors.
- D. Plywood/Gypsum Sheathing:
1. Install new sheathing at walls, roof hatches curbs, and perimeters. Replace damaged, deteriorated, or non-salvageable sheathing.
  2. Secure sheathing to substrate with flat head fasteners (type appropriate for substrate) spaced 12-inches (300mm) on-center.
  3. Secure sheathing to wood substrate with nails spaced 6-inches (150mm) on-center.
- E. Equipment and Curb Renovation:
1. Remove, retain, and reinstall existing equipment as required to facilitate new flashing.
  2. Securely fasten equipment on curbs after new flashing is installed with grommetted screws spaced 12-inches on-center, minimum, two per side of equipment.
  3. Curb and hatch flashing height shall be 8-inches (200mm) minimum above newly finished roof surface.
  4. Include raising of curb flashing to provide minimum 8-inch (200mm) height in base bid cost.
- F. Rooftop Equipment:
1. Move and elevate air conditioning units and other rooftop equipment as required to install roofing materials complete and in accordance with plans and specifications.
  2. When units or equipment are to be moved, disconnect and move to protected area to prevent damage to parts or components. Reset and reconnect at Contractor's expense.
  3. Disconnection and reconnection shall be performed by mechanical and/or electrical company licensed to perform such work and approved by Owner's Representative.
  4. Re-install equipment on top of new support curb or existing curb. Secure equipment to curb with grommetted fasteners spaced 12-inches (300mm) on-center, minimum two fasteners per side. Set equipment on top of pre-manufactured support and secure to support.
  5. Install stainless steel strap, one per side, over top of existing equipment and secure through vertical flange and into curb with appropriate fastener.
- G. Curbs and Ducts:
1. Secure and modify curbs, ducts, and other work which pass through roof as required to receive new roofing system.
  2. Seal joints in sheet metal ducts and vent hoods with reinforcing fabric and elastomeric coating. Apply coating to exposed surfaces of ducts and vent hoods.



H. Piping and Conduit Modifications:

1. Schedule piping and unit downtime for equipment modifications to coordinate with Owner's operations. Switchover time shall be limited to meet Owner's requirements.
2. Replace existing supports for units and associated piping with new supports.
3. Provide temporary supports to maintain unit and piping in operational condition except during switchover.
4. Furnish new fittings, piping, and accessories to match existing to replace deteriorated, damaged, or non-functional components or to accommodate new unit elevation, where necessary.
5. Provide auxiliary make-up air units to supply HVAC needs during equipment downtime, when required.
6. Upon completion of roof installation, paint steel piping with exterior grade acrylic paint and replace or clean aluminum jacketing of insulated pipe.

I. Piping Supports:

1. Furnish and install new supports for piping (conduit, gas, water, condensate, etc.).
2. Install supports at maximum spacing of 10 feet (3m) on-center and within 2 feet (600mm) of changes in plane or direction. Space supports for piping 10-inches (250mm) in diameter or larger and multiple pipes 8 feet (2.4m) on-center.
3. Install new crossover positioned over sections of ducting and/or piping for access to roof areas in designated locations.

J. Roof Drains and Sleeves to Remain:

1. Secure and modify drains and sleeves to receive new roofing system.
2. Verify drain bowls and pipes are properly secured and sealed.
3. Remove, replace, lower, or raise drain bowl as required to accommodate new roofing system, including insulation and deck conditions.
4. Replace damaged, missing, or otherwise non-salvageable drain components with new components. Replace plastic strainers with cast iron units.
5. Drill and tap existing drain bowls as required for complete assembly of drain. Secure clamp rings with stainless steel bolts and washers. Clamp rings to be secured throughout project. Wire brush, clean, and paint existing cast iron clamp rings and strainers to be reinstalled.
6. Water test each roof drain with inflatable plug. Position plug in leader so test will cover connection of pipe to bowl. Extend "test" water on top of roof membrane beyond clamping ring. Maintain "test" water for one hour while performing interior observations for water leakage. Replace drain bowl assemblies that cannot be made watertight during leak test.
7. Paint new strainers and clamp rings prior to installation.

K. Plumbing Vents:

1. Extend plumbing vents or modify as necessary to accommodate new roof installation.
2. Provide pipe extensions and no-hub couplings where necessary to achieve minimum 8-inch (200mm) height above top of newly finished roof surface.
3. Utilize same material type and size as existing for new extension.

- L. Ventilators: Raise ventilators as required for 8-inch (200mm) minimum flashing height.
- M. Sheet Metal Fabrications:
  - 1. Remove and replace ferrous rooftop sheet metal fabrications to match existing.
  - 2. Modify existing sleeves and umbrellas on existing equipment as scheduled.
  - 3. Repair and renovate non-ferrous rooftop and drainage system sheet metal fabrications as required for permanent watertight installation.
  - 4. Paint sheet metal with metal primer. Paint existing equipment hoods, covers, heat-flues/exhausts, steel framed supports, and other rooftop related exposed steel, penetration sleeves, and other sheet metal items to remain. Use rotary wire wheel or other mechanical abrading method to remove corrosion on sheet metal surfaces down to bare sound metal. Clean prepared areas and adjacent surfaces to receive new paint. Apply paint to prepared and cleaned surfaces in adequate coverage utilizing napped rollers to achieve monolithic finish appearance. Utilize heat resistant paint at heat exhaust vents.

**3.05 CLEANING:**

- A. Materials, equipment, and debris resulting from demolition operations shall become property of Contractor. Remove and dispose of demolition debris in accordance with applicable city, state, and federal laws at authorized disposal site.
- B. Leave substrate clean and dry, ready to receive roofing system.

**END OF SECTION 02 07 20**

**SECTION 07 22 00**

**ROOF AND DECK INSULATION**

**PART ONE - GENERAL**

**1.01 SECTION INCLUDES:**

- A. Installation of flat-stock polyisocyanurate, tapered polyisocyanurate insulation, and gypsum roof cover board as designated on the applicable roof areas.

**1.02 RELATED SECTIONS:**

- A. 07 52 00 – Modified Bitumen Membrane Roofing System.

**1.03 REFERENCES:**

- A. American Society for Testing and Materials (ASTM).
- B. Standards:
  - 1. FM Global Approval Guide.
  - 2. Underwriters Laboratories: Building Materials Directory.
  - 3. National Roofing Contractors Association (NRCA): The NRCA Roofing and Waterproofing Manual, latest edition.
  - 4. ASCE 7-05: "Minimum Design Loads for Buildings and Other Structures."
  - 5. Polyisocyanurate Insulation Manufacturer's Association: Technical Bulletin 109 – "Storage and Handling Recommendations for Polyisocyanurate".

**1.04 QUALITY ASSURANCE:**

- A. Regulatory Requirements:
  - 1. Classified by Underwriters Laboratories Inc. as Class A rated material.
  - 2. Follow local, state, and federal regulations, safety standards, and codes. When conflict exists, the more restrictive document shall govern.
- B. Installation:
  - 1. Install in accordance with manufacturer's current published application procedures and general requirements of NRCA.
  - 2. Consider roof system manufacturer's technical specifications part of this Specification and use as reference for specific application procedures.
  - 3. Provide and install roof system to meet or exceed wind uplift resistance pressures of 105 psf in the field, 165 psf along the perimeter of the roof, and 225 psf in the corners of the roof in accordance with ASCE 7-05 and assuming 110 mph wind speed, Exposure B, Enclosed Building, Importance Factor of 1.15, and a Safety Factor of 2.0.

**1.05 DELIVERY, STORAGE, AND HANDLING:**

- A. Store materials in accordance with manufacturer's recommendations.
- B. Outdoor Storage:
  - 1. Tarp and shield insulation from moisture and ultraviolet rays.
  - 2. Elevate insulation above substrate 4-inches minimum.
  - 3. Secure insulation to resist high winds.

4. Do not use insulation which has been determined "wet" or which has been wet and has dried.
5. Distribute insulation stored on roof deck to prevent concentrated loads that would impose excessive stress or strain on deck or structural members.
6. Remove manufacturer plastic shrink wrapping from materials.

**1.06 SEQUENCING AND SCHEDULING:**

- A. Plan roof layout with respect to roof deck slope to prevent rainwater drainage into completed roofing.
- B. Do not install more insulation than can be made watertight in same day.

**1.07 PROJECT CONDITIONS:**

- A. Environmental Recommendations:
  1. Apply roofing and insulation in dry weather.
  2. Do not proceed with roof construction during inclement weather or when precipitation is predicted with 30 percent or more possibility.
  3. Do not apply insulation over wet or moist deck or in foggy conditions.
  4. Consider days when wind speeds are 30 mph or greater as "bad weather" days.
- B. Maintain on site equipment and material necessary to apply emergency temporary weather protection in event of sudden precipitation.

**PART TWO - PRODUCTS**

**2.01 ROOF INSULATION:**

- A. Polyisocyanurate Insulation: Rigid, closed cell polyisocyanurate rigid board insulation utilizing non-chlorine/non-ozone depleting blowing agent, bonded to non-asphaltic coated fiberglass facers, ASTM C 1289, Type II, Class 2, Grade 2 (20 psi), 3.5-inch thickness; maximum board size 4 feet by 8 feet boards for mechanically attached applications; such as "ACFoam-III" by Atlas Roofing Corp, "ENRGY AGF or CGF" by John Manville, "Paratherm CG" by Siplast, or approved equal.
- B. Tapered Polyisocyanurate Insulation: Rigid, closed cell tapered polyisocyanurate rigid board insulation utilizing non-chlorine/non-ozone depleting blowing agent, bonded to non-asphaltic coated fiberglass facers, ASTM C 1289, Type II, Class 2, Grade 2 (20 psi), to achieve ¼-inch resulting slope; such as "Tapered ACFoam-III" by Atlas Roofing Corp, "Tapered ENRGY AGF or CGF" by John Manville, "Tapered Paratherm CG" by Siplast, or approved equal.
- C. Cover Board: Moisture-resistant, 1/2-inch thick X 4-feet X 4-feet size gypsum-based roof board such as "Dens Deck Prime" by Georgia Pacific or "SecuRock" by US Gypsum.
- D. Tapered Edge Strip: Tapered perlite insulation complying with ASTM C-728, to be used for tapered edge strips, size 1/2-inch (13mm) to 1-1/2-inch (37.5mm) thick by 6-inches (150mm) to 24-inches (600mm) wide, suitable for site conditions, such as "Tapered Fesco Edge Strip" by Johns Manville.

**2.02 RELATED MATERIALS:**

- A. Heat Resistant Insulation: Molded hydrous calcium silicate-based or perlite-based heat resistant rigid pipe insulation, 2-inches in thickness and sized for installation around circular/tubular element such as "Sproule Pipe Insulation" or "Thermo-12 Gold" by Industrial Insulation Group, 800/334-7997.
- B. Compressible Fill Insulation: Foil or paper faced compressible fiberglass batten roll insulation of proper size and thickness to insert at openings at penetrations, perimeters, and curbs such as manufactured by Owens Corning.
- C. Insulation Fasteners - Steel Deck: CR-10 fluorocarbon coated, self-tapping screws of sufficient length to penetrate the steel deck a minimum of 1-inch (25mm), minimum 3-inch (75mm) diameter steel plates with recessed screw head for use with insulation, such as "#15 Heavy Duty Roofing Fastener", "#21 Extra Heavy Duty Roofing Fastener", or approved equal such as manufactured by OMG, or fastener approved by manufacturer as required to achieve the desired wind uplift resistance.
- D. Low-Rise Foam Insulation Adhesive:
  - 1. Single-component Moisture-cured Adhesive: ASTM D-2126, dispensed from portable pressurized containers, such as "DerbiBond LR" by DerbiGum, "Insta-Stik Professional Roofing Adhesive" by Dow Chemical Co., "Para-Stick" by Siplast, or approved equal
  - 2. Dual-component Reaction-cure Adhesive: Two-part spray-applied low-rise urethane foam adhesive such as "OlyBond 500" by OMG, "JM Two-Part Urethane Insulation Adhesive" by Johns Manville, or approved equal.

**PART THREE - EXECUTION**

**3.01 EXAMINATION:**

- A. Roof system manufacturer's representative shall inspect roof deck and associated substrates and provide written acceptance of conditions.
- B. Manufacturer's approved roofing contractor shall inspect and approve deck and substrates.
- C. Roofing contractor shall examine roof deck and related substrates and verify that there are no conditions that would prevent roof system manufacturer's approved application of roof system. These conditions include, but are not limited to, the following:
  - 1. Inadequate anchorage of decking or substrates to structure.
  - 2. Accumulations of moisture.
  - 3. Tears, holes, cracks, or punctures.
  - 4. Ridges, uneven conditions, or gaps.
  - 5. Rust or other forms of deterioration.
  - 6. Presence of foreign materials.
- D. Start of work constitutes acceptance of substrate and site conditions.

**3.02 PROTECTION:**

- A. Provide special protection from traffic on newly installed roof.

**3.03 PREPARATION:**

- A. Do not install insulation until defects in roof deck and substrates are corrected in order to meet roof system manufacturer's requirements and to ensure that deck conditions will not restrict roof drainage.
- B. Broom sweep and clean areas to receive new insulation.
- C. Perform pull-out resistance tests in general accordance with ANSI/SPRI FX-1-2006 with the specified insulation fastener on the existing fluted steel roof deck. Provide results of pull-tests to the Roof System Manufacturer and Engineer/Consultant for determination of fastener spacing.

**3.04 APPLICATION:**

- A. General Insulation Installation:
  - 1. Install insulation with longitudinal joints continuous and end joints staggered.
  - 2. Install insulation layers to roof deck in strict accordance with manufacturer's criteria to resist designated minimum wind uplift pressures.
  - 3. Field cut and fit insulation boards at penetrations and curbs.
  - 4. Stagger all joints (side and end) between layers of insulation.
- B. Mechanically Attached Insulation Layer:
  - 1. Mechanically attach insulation layers and membrane base ply to deck.
  - 2. Install insulation so that insulation board ends and sides bear completely on ribs of the steel deck a minimum of 1/2-inch (13mm).
  - 3. Install insulation with longitudinal joints continuous and end joints staggered.
  - 4. Mechanically fasten insulation layers to roof deck in strict accordance with manufacturer's criteria to achieve specified wind uplift resistance.
  - 5. Fully engage and seat fasteners. Do not overtighten or strip threads. Bent, deformed, or unseated fasteners or plates are unacceptable.
  - 6. Fasteners must penetrate deck 1/2-inch (13mm), minimum, through the top flange (rib) of the deck. Do not overdrive fasteners. Remove and replace overdriven, stripped, or non-engaged fasteners.
  - 7. Properly seat mechanical fasteners and keep heads flush with plates. Cupped plates or unseated screw heads are not acceptable.
  - 8. Do not rupture or deform surface of the insulation by mechanical fastening.
- C. Adhered Layers of Insulation:
  - 1. Adhere insulation to concrete deck or previously installed layers of insulation.
  - 2. Butt joints tightly allowing no more than 1/4-inch (6mm) wide gaps between units. Fill joints between adjacent boards with like insulation or spray-foam adhesive.
  - 3. After installation of initial layer of insulation, install subsequent layers of insulation directly over preceding layer.
  - 4. Install tapered insulation in field of roof to achieve a resulting 1/4-inch per foot (minimum) slope on designated roof areas.
  - 5. Field cut tapered insulation boards to create crickets at upslope sides of curbs and along walls.
  - 6. Install tapered edge strips at changes in elevations, edges of crickets, and other locations to create monolithic and uniform substrate for installation of roof cover board and membrane.

7. Adhere tapered insulation, tapered crickets, and tapered edge strips over the substrate or fill layer. Adhere cover board over the preceding layers to form the substrate to receive the roof membrane base ply.
- D. Ribbon Application (Low-rise Foam Adhesive):
1. Dispense 3/4-inch to 1-inch (19mm to 25mm) diameter continuous ribbons of adhesive on substrate to adhere insulation board.
  2. Place the initial ribbon of adhesive 3-inches (75mm) inside each edge/side of the insulation board in a picture-frame fashion. Apply additional parallel ribbons of adhesive across the remainder of the board in a serpentine fashion and spaced approximately 12-inches (300mm) on-center in the field of the roof; spaced 6-inches (150mm) on-center in a 8-foot wide area along the roof perimeter, and 3-inches (75mm) on-center in 8-foot by 8-foot areas at corners or spacing as required to achieve designated wind uplift resistance.
  3. Firmly set insulation boards in the ribbons of foam adhesive following application of the adhesive when adhesive has risen to proper height and walk-in the insulation to spread the adhesive ribbons, ensuring maximum contact. Do not push or slide insulation into position. Set weighted objects on ends, sides, and corners of boards until adhesive has set and insulation is firmly attached (approximately 20 to 45 minutes).
  4. On additional insulation layers, dispense ribbons of adhesive in direction perpendicular to the direction of the beads that were dispensed on the underlying layer.
  5. Fill voids or open joints in top layer of insulation with spray-foam adhesive to provide monolithic surface to receive new membrane.
  6. Adhere partial boards and tapered edge strips with adhesive ribbon positioned in picture-frame fashion along perimeter of board and remaining adhesive ribbons spaced in accordance with location on roof (field, perimeter, or corner).
  7. At end of each work day, provide staggered ends of installed boards so that proper joint stagger can be achieved on following roof installation.

**3.05 CLEANING:**

- A. Remove debris and material wrappers from roof to dumpster daily. Leave insulation clean, dry, and ready to receive new roofing.

**3.06 ADJUSTING:**

- A. Remove damaged insulation, components, or accessories and install acceptable new units.

**3.07 PROTECTION:**

- A. Provide special protection from traffic on completed work.

**END OF SECTION 07 22 00**

**SECTION 07 52 50**

**MODIFIED BITUMEN MEMBRANE ROOFING**

**PART ONE - GENERAL**

**1.01 SECTION INCLUDES:**

- A. Installation of new two-ply modified bitumen roof system and related flashings on subject roofs.

**1.02 RELATED SECTIONS:**

- A. 02 07 20 - Minor Demolition and Renovation Work.
- B. 07 22 00 - Roof and Deck Insulation.
- C. 07 62 00 - Sheet Metal Flashing and Trim.

**1.03 REFERENCES:**

- A. American Society for Testing and Materials (ASTM).
- B. Standards:
  - 1. FM Global Approval Guide.
  - 2. Underwriters Laboratories: Building Materials Directory.
  - 3. National Roofing Contractors Association (NRCA): The NRCA Roofing and Waterproofing Manual, latest edition.
  - 4. ASCE 7: "Minimum Design Loads for Buildings and Other Structures."
  - 5. SPRI "Application Guidelines for Modified Bitumen Roofing Systems".
  - 6. Cool Roof Rating Council (CRRC).
  - 7. FMGlobal Property Loss Prevention Data Sheets
    - a. DS 1-28 "Wind Design".
    - b. DS 1-29 "Roof Deck Securement and Above-deck Roof Components".
    - c. DS 1-33 "Safeguarding Torch-applied Roof Installations"
    - d. DS 1-49 "Perimeter Flashing".
    - e. DS 1-52 "Field Verification of Roof Wind Uplift Resistance".

**1.04 QUALITY ASSURANCE:**

- A. Application:
  - 1. Approved by manufacturer of accepted roofing system.
  - 2. A single applicator with a minimum of five years previous successful experience in installations of similar systems.
- B. Manufacturer Requirements:
  - 1. Roof Membrane Assembly: Classified by Underwriters' Laboratories, Inc. as a Class A roof covering with no slope limitations.
  - 2. Roof Membrane Assembly: Classified by FM Global as a Class 1, approved assembly and Class 1-SH (Severe Hail) exposure.
  - 3. Manufacturer to have direct actual in-house experience in the manufacturing of the specified products for a period of a minimum of twenty years.



4. Manufacturer to have documented project history of installation of the specified products in the United States for a period of a minimum of twenty years.
  5. Manufacturer to provide authorized documentation of the physical/ mechanical properties from the testing laboratory of Manufacturer of the actual materials utilized for the project indicating compliance with applicable ASTM standards D 5147 and D 6298.
  6. Manufacturer's products shall comply with the following standards:
    - a. Polyester/Fiberglass composite reinforcement SBS modified bitumen sheet, ASTM D 6162, Grade S or G, Type 1 – 3.
    - b. Fiberglass-reinforced SBS modified bitumen sheet, ASTM D 6163, Type 1 – 3, Grade S or G.
    - c. Polyester-reinforced SBS modified bitumen sheet, ASTM D 6164, Type 1 – 3, Grade S or G.
    - d. Polyester-reinforced APP modified bitumen sheet, ASTM D 6222, Type 1 or 2, Grade S or G.
- C. Regulatory Requirements:
1. Products Manufactured in the United States.
    - a. Classified by Underwriters' Laboratories, Inc. as a Class A roof covering.
    - b. Classified by FM Global as a Class 1-A approved assembly.
    - c. Provide and install roof system to meet or exceed wind uplift resistance pressures of 105 psf in field of roof; 165 psf along perimeter of roofs; and 225 psf in corners of roof in accordance with ASCE 7-05 assuming 110 mph wind speed, Exposure B, Enclosed Building, Importance Factor of 1.15, Safety Factor of 2.0; and Eave Heights of 150-ft for Penthouse Roof and 137-ft for Main Roof. Perimeter Zone is 8-feet wide for Main roof and 4-feet wide for Penthouse roofs. Corner Zone is 8-feet X 8-feet for Main roof and 4-feet X 4-feet for Penthouse roofs.
  2. Follow federal regulations, safety standards, and codes mandated in the United States related to the subject work.
- D. Laboratory Testing and Samples:
1. At Owner's request, obtain field samples of the completed roof membrane, laps, and/or assembly.
  2. Take samples at locations designated by Consultant and test for compliance with the requirements on the Contract Documents and with manufacturer's published performance criteria.
  3. Perform test in accordance with accepted ASTM methods.
  4. Assume all costs for extraction and patch of all samples. Owner shall assume all costs for testing of field sample.
  5. Correct all deficiencies in accordance with the manufacturer's recommended procedures at no cost to Owner.
  6. If for any reason, areas that are tested by Owner fail to meet manufacturer's requirements, then all subsequent expense for retesting of those areas will be borne by Contractor.

- E. Installation:
  - 1. Install in accordance with manufacturer's current published application procedures and the general recommendations of the NRCA.
  - 2. Upon completion of installation, an inspection shall be conducted by a technical representative of the manufacturer to certify that roofing system has been installed according to manufacturer's most current published specifications and details.
  - 3. Roofing as described in this Section shall be provided and/or approved by roof system manufacturer.
  - 4. Obtain written approval from the manufacturer for any materials not manufactured or provided by manufacturer stating that materials are acceptable and are compatible with other materials and systems required.
  - 5. Personnel designated to utilize propane torching equipment to install roofing materials must have current CERTA safety certification issued by MRCA.
- F. Make no deviations made from this Specification or the approved shop drawings without prior written approval of Owner's Representative and roof membrane manufacturer.
- G. Perform entire work of this Section in accordance with the best standards of practice relating to the trades involved.

**1.05 DELIVERY, STORAGE, AND HANDLING:**

- A. Deliver materials in manufacturer's original, unopened containers or packages with labels intact and legible.
- B. Store materials in accordance with manufacturer's recommendations. Store rolled goods on clean raised platforms. Store other materials in dry area, protected from water and direct sunlight, and maintain at a temperature of 16 to 27 degrees Celsius.
- C. Provide continuous protection of materials against deterioration.
- D. Materials Stored on Roof Levels for Immediate Use:
  - 1. Distribute to prevent concentrated loads that would impose excessive strain on deck or structural members or restrict positive drainage.
  - 2. Positively secure to prevent displacement by wind.
  - 3. Tarp for protection from exposure.
  - 4. Cut and remove manufacturer's plastic "shrink wrapping" from materials during storage.

**1.06 PROJECT CONDITIONS:**

- A. Existing Conditions: Examine existing building and existing roofing and decking to determine physical conditions that affect removal of existing roofing and installation of new roofing.
- B. Environmental Requirements:
  - 1. Apply roofing in dry weather.
  - 2. Do not remove existing roofing and flashing in inclement weather or when rain is predicted (30 percent or more possibility).

3. Do not remove existing roofing and flashing when ambient temperature is below 4 degrees Celsius.
  4. Do not expose membrane and accessories to a constant temperature in excess of 82 degrees Celsius.
- C. Protection:
1. Provide special protection or avoid heavy traffic on completed work when ambient temperature is above 26 degrees Celsius.
  2. Restore to original condition or replace work or materials damaged during handling or roofing materials.
- D. Emergency Equipment: Maintain on-site equipment necessary to apply emergency temporary protection of roof and building in the event of sudden storms or inclement weather.

**1.07 SEQUENCING AND SCHEDULING:**

- A. Do not remove more existing roofing in one day than can be replaced with new roofing and flashing in same day.

**1.08 WARRANTY:**

- A. Submit to Owner, prior to final payment, two copies of the following warranties:
1. Roofing Material Manufacturer's Warranty: Project shall be installed in such a manner that the roof system manufacturer will furnish a written full-system (including, but not limited to, insulation layers, fasteners, adhesives, flashing sheets, etc.), no dollar limitation, labor and material warranty agreeing to replace/repair defective materials and workmanship, for a warranty period of twenty years after date of written final acceptance by Owner.
  2. Contractor's Warranty: In addition, furnish a written warranty agreeing to repair/replace defective installation and workmanship labor causing leakage of water, deterioration of materials, and other failures of the installed system, sealants, painting, coatings, and related work on this project, to perform as required within the warranty period. Warranty period is two years after date of written final acceptance by Owner.

**PART TWO - PRODUCTS**

**2.01 MANUFACTURER:**

- A. Modified Bitumen Roofing Manufacturers
1. Siplast.
  2. DerbiGum.
  3. Johns Manville.
  4. Soprema.
  5. Firestone.
  6. Certainteed.
  7. Or approved equal.

**2.02 SHEET MATERIALS:**

A. Roof Membrane:

1. SBS Membrane:

- a. SBS Membrane Base Ply: Smooth surfaced, polyester reinforced, SBS modified bitumen sheet, suitable for heat-welding/torching such as "Paradiene 20 PR TG" by Siplast or "or "DynaWeld 180S" or "DynaBase PR" by Johns Manville", "Sopralene Flam 180" or "Sopralene 180 PS" by Soprema, or approved equal.
- b. SBS Membrane Top Ply: Granule-surfaced, polyester/fiberglass reinforced, SBS modified bitumen sheet, suitable for heat-welding/torching such as "Paradiene 30 CR FR BW TG" by Siplast or "Sopralene Flam 180 FR GR SG" by Soprema; "DynaWeld Cap 180 CR FR G" by Johns Manville, or approved equal.
- c. SBS Base Flashing: One-ply of specified membrane base ply and one ply of top sheet or polyester-reinforced SBS modified bitumen flashing sheet with same finish as cap sheet.

2. APP Membrane:

- a. APP Membrane Base Ply: Smooth surfaced, polyester reinforced, torch-applied APP modified bitumen sheet such as "DerbiBase HV" by DerbiGum, "APP 160" by Firestone, "Flintlastic STA" by Certainteed, or approved equal.
- b. APP Membrane Top Ply: Granule-surfaced, white color, polyester/fiberglass reinforced, APP modified bitumen sheet suitable for application with cold-adhesive or heat-welding/torching such as "DerbiColor P CR FR" by DerbiGum, "APP 180 FR UltraWhite" by Firestone, "Flintlastic GTA FR CoolStar" or approved equal.
- c. APP Base Flashing System: One-ply of specified membrane base ply and one ply of specified top ply or approved equal.

**2.03 RELATED MATERIALS:**

- A. Asphalt Primer: ASTM D 41.
- B. Edge Sealant: Rubberized asphaltic plastic roof cement that is gun-grade version for sealing top edges of base flashings and terminations of cap sheet such as "Elastomastic 209" by Henry Co.
- C. Elastomeric Plastic Roof Cement: Rubberized plastic roof cement/adhesive such as "PA-1021" by Siplast, "PerFlash" by DerbiGum, "MBR Flashing Cement" by Johns Manville, or approved equal to be used for temporary seals of flashings, embedding sheet metal flanges, and three coursing of seams and cuts in modified bitumen sheets.
- D. Reinforcing Fabric: 6-inch wide asphalt coating fiberglass or polyester mesh.
- E. Fasteners - Steel Deck: CR-10 fluorocarbon coated, self-tapping screws of sufficient length to penetrate the steel deck a minimum of 1-inch (25mm), minimum 3-inch (75mm) diameter steel plates with recessed screw head for use with insulation, such as "#15 Heavy Duty Roofing Fastener" or "#21 Extra Heavy Duty Roofing Fastener" as manufactured by OMG, or approved fastener required to attached roof membrane to achieve the desired wind uplift resistance.

- F. Liquid Flashing System: Fluid-applied reinforced flashing system to apply around roof penetrations, low-profile flashing substrates, or other suitable locations that would be included in the warranty coverage for the roof membrane system, "Parapro" by Siplast", "DerbiFlash" by Derbigum, "SeamFree PMMA Flashing" by Johns Manville, "Alsan" by Soprema, "UltraFlash" by Firestone, "SmartFlash" by Certainteed, or approved equal.

**2.04 MISCELLANEOUS MATERIALS:**

- A. Best grade or quality approved by the manufacturer for the specific application.

**PART THREE - EXECUTION**

**3.01 EXAMINATION OF SURFACES:**

- A. Contractor shall examine the substrate, roof deck, and related surfaces and verify that there are no conditions such as inadequate anchorage, foreign materials, moisture, ridges, or other conditions which would prevent the satisfactory installation of the roofing system.
- B. Correct or complete any condition requiring correction or completion prior to the installation of the roofing system. Notify Owner's Representative in writing of unacceptable conditions.
- C. Verify the location of all interior ducts, electrical lines, piping, conduit, and/or similar obstructions. Perform all work in such a manner as to avoid contact with the above-mentioned items.
- D. Start of work under this Part Three constitutes acceptance of substrate and site conditions.

**3.02 PREPARATION:**

- A. Do not stockpile debris on roof surface.
- B. Promptly remove debris each day. Use hoist to transfer debris from roof surface to disposal container.
- C. Cleaning:
  - 1. Verify that debris has been completely removed.
  - 2. Broom clean and airblow substrate immediately prior to surface preparation.

**3.03 APPLICATION:**

- A. Prior to roof membrane installation, seal all openings, projections, and penetrations in the substrate to prevent entry of materials into the building. Correct damage to the building or interior components caused by material entry.
- B. Membrane Installation - General:
  - 1. Apply roofing in accordance with roofing system manufacturer's instructions and the following requirements.
  - 2. The overall appearance of the finished roof application is a standard requirement for this project. Make necessary preparations, utilize recommended application techniques, apply specified materials, and exercise care to ensure finished application is acceptable to Owner's Representative.

3. Prime top and bottom of metal surfaces (flashing flanges, lead drain flashings, etc.), concrete surfaces, and masonry surfaces with a uniform coating of asphalt primer, at a nominal rate of 1 gallon/100 square feet (3.8 liters per 9.29 square meters).
  4. Place cant strips on top of substrate to form continuous monolithic substrate at walls and curbs. Secure fibrous cants by embedding in ribbons of low-rise foam adhesive or uniform troweling of plastic roof cement, nominal 1/4-inch thick, across entire bottom of cant. Miter cut cant strips to form continuous substrate at corners. Adhere cut piece of roof cover board in low-rise foam adhesive over top of fibrous cant.
  5. Lay all layers of roofing free of wrinkles, creases, or fishmouths. Exert sufficient pressure on the roll during application to ensure prevention of air pockets.
  6. Lay layers of roofing perpendicular or parallel to the slope of the deck as recommended by manufacturer.
  7. Install roof system configuration and components as required to meet the requirements of the testing assembly for the respective proposed roof material manufacturer. Provide additional ply of polyester-reinforced base ply mechanically-attached with insulation board to steel deck as required to meet wind uplift criteria.
- C. Membrane Base Ply Application:
1. Install roof system configuration and components as required to meet the requirements of tested assembly for the respective proposed roof material manufacturer. Provide additional ply of polyester-reinforced base ply mechanically-attached with insulation board to steel deck as required to meet wind uplift criteria.
  2. Unroll base ply sheet and cut into 15-foot (5m) lengths. Lay cut sections of sheet down to allow sheet to relax prior to application. Prior to application, re-roll "relaxed" sheet using cardboard insert provided with roll.
  3. Beginning at the low point on the roof, fully adhere the modified bitumen sheet to the substrate. Maintain a steady torching technique to ensure that the entire bottom surface of the sheet achieves the proper temperature for adhesion. Keep the roll in close proximity to the torch technician. Exert sufficient pressure on roll during application.
  4. Apply heat evenly across the face and full width of the roll while unrolling roll uniformly with an even downward pressure. Apply torch flame to roll until the bitumen back coating reaches the design application temperature, resulting in melting of the burn-off film, a glossy appearance of the back coating, and an approximate ¼-inch to ½-inch (6 mm to 13 mm) bitumen flow from edge of sheet.
  5. Fully adhere membrane base ply to substrate and have a minimum of 3-inch (75 mm) side laps and 6-inch (150 mm) end laps. Stagger end laps of adjacent sheets of membrane base ply a minimum of 3-feet (1 m). Extend field sheet of membrane base ply to top edge of cant.

6. Complete membrane base ply application over respective roof area prior to application of membrane top ply. Apply additional ply of membrane base ply in low areas or areas that may be subjected to ponding water. Install base ply at roof drain with side lap centered over drain opening.
  7. Apply a patch over areas of membrane with areas of physical damage or other defects. Patch shall be the full width of membrane base ply and extend a minimum of 2-inches (50 mm) beyond the defect in each direction.
  8. Check lap seams and seal unbonded or discontinuous seams using a heated steel trowel.
- D. Base Flashing Application - Base Ply:
1. Install and complete application of base ply of flashing each day the base ply of membrane is installed.
  2. Install first ply of base flashing extending horizontally 4-inches (100 mm) beyond edge of cant or flange and vertically 4-inches (100 mm), minimum above the top of the cant.
  3. Length of base flashings shall be maximum 6-feet (2 m). Lap ends of base ply flashings 4-inches (100 mm), minimum. Seal top edge of base ply flashing on a daily basis with a continuous troweling of elastomeric roof cement.
  4. Check lap seams and seal unbonded or discontinuous seams of base ply flashing using a heated steel trowel.
  5. For wood substrate, mechanically attach a base sheet 8-inches (200mm) on-center in all directions and along lap seams, overlapping adjacent sheets 4-inches (100mm), minimum. Adhere modified bitumen base ply flashing to base sheet.
  6. Where existing substrate is deemed unacceptable to install new materials, attach plywood or acceptable gypsum sheathing to serve as new substrate for flashing membrane.
- E. Strip-in Flashing:
1. Prime top and bottom of metal flanges and other sheet metal components completely and allow to dry prior to installation.
  2. After membrane base ply has been applied, install metal flange flashings according to Section 07 62 00 - Sheet Metal Flashing and Trim. Strip-in flange/metal with strips of base flashing (base ply) concealing entire flange or horizontal surface of metal flashing and extending a minimum of 4-inches (100mm) beyond edge of flange/metal and heat-fusing strip-in to base ply.
- F. Membrane Application - Top Ply:
1. Unroll top ply and cut into 15 foot lengths. Lay cut sections of top ply down to allow sheet to relax prior to application. Prior to application, re-roll "relaxed" sheet using cardboard insert provided with roll.
  2. Beginning at the low point on the roof, fully adhere membrane top ply to membrane base ply and have a minimum of 3-inches (75 mm) side laps or width of selvage edge and 6-inches (150 mm) end laps. Extend membrane top ply to top edge of cant. Apply each sheet directly behind torch technician. Stagger side laps of top ply a minimum of 12-inches (300 mm) from side laps of base ply.

3. Apply heat evenly across the face and full width of the roll while unrolling roll uniformly with an even downward pressure. Apply torch flame to roll until the bitumen back coating reaches the design application temperature, resulting in melting of the burn-off film, a glossy appearance of the back coating, and an approximate ¼-inch to ½-inch (6 mm to 13 mm) bitumen flow from edge of sheet. Apply heat to top surface of base ply to receive heated cap sheet to develop an initial softening or “tackiness” of top coating.
4. While installing membrane top ply, provide proper protection or method during application to prevent contamination, soiling, charring, or marking the granule surfacing of previously installed sheet. Exert sufficient downward pressure on roll during application. Utilizing appropriate tool, pull the roll toward direction of application while heating bottom portion of roll and substrate. Do not stand on subject sheet during torching process.
5. During end lap application, trim the inside corner along the selvage edge of the underlying sheet at the end of the roll. The trimmed area shall be the width of the selvage edge and extend downward from the end of the roll to the outer side of the roll in a linear direction approximately 5-1/2-inches (138mm) from end of roll. Trim outside corner of membrane top ply at end laps to provide rounded finished corner.
6. On colored-granulated sheet, embed colored granules into bituminous bleed-out along edges of cap sheet to provide monolithic surface color. On white-surfaced sheet, apply elastomeric coating or surfacing material approved/supplied by manufacturer over bituminous bleed-out along edges of cap sheet to provide monolithic surface color.
7. Install membrane top ply so that end laps of every other sheet is aligned.
8. Roof Drain: Install top ply centered over drain opening extending under clamping ring. Apply elastomeric plastic cement and reinforcing fabric on sheet to cover cuts made to conform sheet to sump. Install clamping ring and secure.
9. Apply a patch over areas of membrane with displaced top bitumen coating or other defects. Patch shall be the full width of membrane top ply and extend a minimum of 2-inches (50 mm) beyond the defect in each direction.
10. Check lap seams and seal unbonded or discontinuous seams using a heated steel trowel.
11. At sheet metal flashings, apply membrane top ply and terminate at the rise in the metal component. Apply a continuous bead of edge sealant along edge terminations of modified bitumen sheet (i.e. flashing flanges, exhaust vents, metal edge, etc.). Bead of edge sealant shall match height of top sheet surfacing and shall be “canted” to shed water. Embed loose granules or coat with elastomeric coating, color to match top ply, into newly installed edge sealant.



**G. Base Flashing Application - Top Ply:**

1. Apply top ply of flashings only after membrane top ply is in place.
2. "Torch de-granulate" granulated surfaces of flashings to receive flashing. Pre-heat the subject area of the underlying granule-surfaced sheet so that granules can be "depressed" or sunk into the compound and the bitumen compound exudes up through the granules to result in a bituminous material-to-bituminous material contact.
3. Cut modified bitumen flashing membrane to extend a minimum of 4-inches (100 mm) above the top of the membrane top ply covering the cant. The overall minimum height of the top of the flashing membrane above the top of the roof surface is 8-inches (200 mm). Extend flashings to full height of vertical substrate.
4. Extend the flashing membrane horizontally 4-inches (100 mm) onto the field of the roof surface beyond the bottom edge of the cant strip.
5. Cut flashing from roll using selvage edge as lap seam for adjacent sheets resulting in sheet lengths of nominal 3-feet (1 m). Lap ends a minimum of 4-inches (100 mm) and stagger laps from laps of underlying plies.
6. Fully adhere and conform top ply of flashing to substrate. Extend bleed-out of applied base flashing a minimum of ½-inch (13 mm) beyond the side or end lap.
7. Mechanically attach top edge of modified bitumen membrane flashing with termination bar and appropriate fasteners spaced 6-inches (150 mm) on-center. Apply continuous troweling of elastomeric plastic roof cement and reinforcing fabric along top edge of base flashing.
8. Walls: Mechanically attach top edge of modified bitumen membrane flashing with appropriate fasteners and termination bar. Fastener spacing shall be 6-inches (150 mm) on-center. Apply three-coursing consisting of an initial continuous troweling of elastomeric plastic roof cement, embedded reinforcing fabric, and a secondary application of elastomeric plastic roof cement along and concealing the top edge of base flashing and termination bar.
9. Curbs: For curbs with non-removable hoods/covers/units, extend flashing to full height of curb, mechanically attach top edge of flashing with termination bar with appropriate fasteners secured 6-inches (150 mm) on-center and apply three-coursing of plastic cement and reinforcing fabric. For curbs with removable hoods/covers/units, wrap flashing sheet over top of curb, secure to top or inside of curb with sheet metal angle termination bar and appropriate fasteners spaced 6-inches (150 mm) on-center.
10. Apply a boot or oval section of modified bitumen sheet over outside corners of curb flashings to conceal cuts in flashing material at corner laps.
11. Install flashing sheets on adjoining perpendicular sides (outside corners) of curbs or walls so that outside corners of flashing sheet align and are rounded.
12. Apply a three-coursing of elastomeric plastic roof cement and reinforcing fabric at vertical lap seams. Extend three-coursing under termination bar. Utilize masking or duct tape to create vertical straight edge of three-coursing. After application of three-coursing, remove tape. Embed granules into plastic cement, immediately after application, to achieve uniform base flashing color.

H. Metal Flange Flashing:

1. Apply membrane top ply and terminate at the rise in the metal component.
2. Apply a target around penetrations or utilize flashing method to conceal cuts in the membrane top ply.
3. Apply a continuous bead of edge sealant along edge terminations of modified bitumen sheet (i.e. flashing flanges, exhaust vents, metal edge etc.). “Cant” bead of edge sealant to shed water. Embed loose granules in newly installed edge sealant and apply coating to match finish of top ply, where applicable.

I. Liquid-Flashings

1. Apply liquid flashing system around penetrations and along walls where suitable traditional ply sheet or sheet metal flashings cannot be installed. Apply liquid flashings in accordance with the manufacturer’s application guidelines at applicable select locations.
2. Apply liquid flashing system on roof membrane within narrow “gutter/drainage” areas between sloped roof areas as designated on Area “C”.
3. Clean penetrating element or approved substrate to receive liquid flashing system.
4. Apply masking tape on substrate to create straight-edge terminations of the liquid flashing system.
5. Embed reinforcing fabric in the liquid flashing system to form monolithic flashing with the finished roofing membrane.
6. Apply reinforced liquid flashing system on top of cap sheet in an area 3-feet X 3-feet around each primary roof drain. Embed granules, color to match cap sheet, in surface of liquid flashing.
7. Apply finish granule surfacing on the liquid flashing system to match the granule color of the finished top ply of the roof membrane.

J. Daily Seal:

1. Install temporary night seal at completion of each day’s work and remove upon resumption of work.
2. Ensure that water does not flow beneath any completed sections of the membrane system. This will include completion of all flashings, terminations, and daily seals. When possible, install starting at the highest point of the project area, working to the lowest point.
3. Seal membrane edge with continuous troweling of plastic roof cement. Caution must be exercised to ensure that membrane is not temporarily sealed near drainage medium in such a way to promote water migration below the membrane or impede drainage.
4. Install primary night seal beneath daily night seal in such a manner to seal both new and existing roof system to roof deck to prevent moisture migration from either old roof or new roof.
5. Install daily night seals by extending the new roof membrane beyond the insulation and sealing to the existing roof surface using plastic cement.
6. When work is resumed, remove and dispose of membrane where cement or other sealants were previously applied before resuming installation.

- K. Daily Fire Watch: Contractor personnel to perform daily "Fire Watch" a minimum of two hours upon completion of heat-fusing installation methods. Contractor to utilize an infrared-sensing thermometer or similar equipment that can provide instant detection of elevated and/or different temperatures of roofing materials. If elevated or suspect temperatures or underlying conditions are detected, contractor to remove necessary materials and perform necessary actions to alleviate the noted condition.

**3.04 FIELD QUALITY CONTROL:**

A. Inspections:

1. During installation, provide for on-site inspections by a technical representative of roof membrane manufacturer.
2. Upon completion of installation, provide final inspection by a technical representative of roof membrane manufacturer.

**3.05 CLEANING:**

- A. Remove debris, adhesives, and sealants from surfaces.
- B. Remove debris and material waste from Project site.

**END OF SECTION 07 52 50**

**SECTION 07 62 00**

**SHEET METAL FLASHING AND TRIM**

**PART ONE - GENERAL**

**1.01 SECTION INCLUDES:**

- A. Shop or field-formed sheet metal work for moisture protection.
- B. Types of work specified in this Section include:
  - 1. Roof penetration sleeves and hood or bonnet.
  - 2. Counter flashing.
  - 3. Roof drains.
  - 4. Coping.
  - 5. Metal gravity vents.
  - 6. Metal heat exhaust vents.
  - 7. Sanitary vent pipes.
  - 8. Pipe box.
  - 9. Curb cap flashing.
  - 10. Metal edge flashing.
  - 11. Scupper, collector heads and downspouts.
  - 12. Equipment straps.
  - 13. Miscellaneous sheet metal accessories.

**1.02 RELATED SECTIONS:**

- A. 02 07 20 - Minor Demolition and Renovation Work.
- B. 07 22 00 - Roof and Deck Insulation.
- C. 07 52 50 - Modified Bitumen Membrane Roofing.

**1.03 REFERENCES:**

- A. American Society for Testing and Materials (ASTM).
- B. Federal Specifications (FS).
- C. National Roofing Contractor's Association (NRCA): NRCA Roofing and Waterproofing Manual, latest edition.
- D. Sheet Metal and Air Conditioning Contractor's National Association, Inc. (SMACNA): Architectural Sheet Metal Manual, latest edition.
- E. ANSI/SPRI ES-1: Fabricate and install sheet metal edge flashings to comply with requirements of ANSI/SPRI ES-1 for 110 mph wind speed.

**1.04 WARRANTY:**

- A. Contractor's Warranty: Provide Owner a written warranty which shall warrant sheet metal work to be free of leaks and defects in materials and workmanship for two years after date of final acceptance by Owner.
- B. For pre-finished metal, provide manufacturer's twenty-year guarantee covering deterioration or failure of the fluoropolymer finish.

## **PART TWO - PRODUCTS**

### **2.01 MANUFACTURERS:**

- A. Acceptable Pre-finished Sheet Metal Manufacturers:
  - 1. Berridge Manufacturing Company.
  - 2. Peterson Aluminum Corporation (PAC CLAD).
  - 3. McElroy.
  - 4. Metal Building Components, Inc. (MBCI).
  - 5. Firestone Metal Co (Una-Clad).
  - 6. Or approved equal.

### **2.02 SHEET METAL MATERIAL:**

- A. Pre-finished Metal: "Kynar 500" or "Hylar 5000" fluoropolymer pre-finished G90 galvanized/galvalume sheet metal, minimum 24 gauge. "Kynar 500" or "Hylar 5000" finish shall consist of a two coat Polyvinyladine flouride, minimum 70 percent by weight in coatings, dry film thickness 1 mil, factory applied by metal manufacturer or supplier. Color selected by Owner from manufacturer's standard color chart.
- B. Zinc-coated (Galvanized) Sheet Metal: Commercial quality with 0.20 percent copper, in accordance with ASTM A 526 except ASTM A 527 for lock forming; coating designation G90 hot-dip galvanized, and mill phosphatized for painting in accordance with ASTM A 525 (paint-grip type), 24 gauge minimum.
- C. Sheet Lead: FS QQ-L-201, Grade B; 2-1/2 pounds per square foot (120n/m<sup>2</sup>) 0.0391-inches (1mm) thick minimum as used for sanitary vent flashing, 4 pounds per square foot (140n/m<sup>2</sup>) 0.0625-inches (1.6mm) thick minimum as used for roof drains.
- D. Stainless Steel Sheet Metal: ASTM A240, Type 304, ASTM A 480, No. 2B/2D Mill Finish, gauge as scheduled.

### **2.03 FASTENERS:**

- A. Fasteners shall be same metal as flashing and sheet metal being joined.
- B. Exposed fasteners shall be self-sealing or gasketed for watertight installation.
- C. Heads of fasteners, including but not limited to, rivets, screws, and bolts, that are exposed or visible shall have same manufactured finishes as item being secured; color to match when applicable.
- D. Mechanical Fasteners:
  - 1. Refer to Section 02 07 20 – Minor Demolition and Renovation Work.
  - 2. Washers: Steel washers with bonded rubber sealing gasket.
  - 3. Screws: Self-tapping sheet metal type compatible with material fastened.
  - 4. Rivets: Stainless steel material for the head and stem, closed end, color to match sheet metal items being adjoined.

### **2.04 RELATED MATERIALS:**

- A. Solder:
  - 1. ASTM B 32, alloy grade 58, 50 percent tin, 50 percent lead.
  - 2. For Use with Stainless Steel: 60-40 tin/lead solder, ASTM B 32.

- B. Flux:
  - 1. Phosphoric acid type, manufacturer's standard.
  - 2. For Use with Steel or Copper: Rosin flux.
  - 3. For Use with Stainless Steel: Acid-chloride type flux, except use rosin flux over tinned surfaces.
- C. Adhesives: Type recommended by flashing sheet manufacturer for waterproof and weather resistant seaming and adhesive application of flashing sheet.
- D. Metal Accessories: Sheet metal clips, straps, anchoring devices, and similar accessory units as required for installation of work, matching or compatible with material being installed, noncorrosive, size and gauge required for performance.
- E. Sealant:
  - 1. Type A: One component polyurethane sealant, ASTM C-920, Type S, Grade NS, Class 35 such as "SikaFlex-1a" by Sika Corp. or "MasterSeal Sonolastic NP1" by BASF, color to match finish of adjoining surface.
  - 2. Type B: One-part low modulus neutral-curing silicone sealant, ASTM C-920, Type S, Grade NS, Class 50 such as "Sikasil WS 290" or "WS 295" by Sika Corp., "795 Silicone Building Sealant" or "790 Silicone Building Sealant" by Dow Corning, or "GE Silpruf SCS 2000" by Momentive Performance Technologies; color to match finish of adjoining surface.
  - 3. Type C: One-component, moisture cure polymer sealant available in over 175 standard colors to match sheet metal flashings in exposed applications such as "Tite Bond Weather Master Sealant" by Franklin International.
  - 4. Type D: Self-adhering preformed 100% solids elastomeric butyl tape, 1/4-inch thick by 3/4-inch wide, such as "TremPro 691" by Tremco.
  - 5. Type E: One-part gun grade butyl rubber sealant such as "TremPro 651" by Tremco.
- F. Base Material for Flashing Pans:
  - 1. Flashing Pans 12-inch by 12-inch and Smaller: Quick-setting grout formula meeting Corps of Engineers specification CRD-C-621, Type D and ASTM C-1107, Grade C, such as "Five Star Instant Grout" by Five Star Products, Inc., "Sika Grout 212" by Sika Corp., or approved equal.
  - 2. Flashing Pans Larger than 12-inch by 12-inch: Spray-foam such as "FrothPak" by InstaFoam.
- G. Pourable Sealer:
  - 1. Pourable polyurethane sealer, approved by roofing system manufacturer.
  - 2. Acceptable Products:
    - a. "Pourable Sealer S-10" by Firestone.
    - b. "1-Part Pourable Sealer" by Chem-Link.
- H. Termination Bar: 1/8-inch (3mm) thick, 1-inch (25mm) wide extruded aluminum bar with flat profile, factory punched oval holes (1/4-inch by 3/8-inch [6mm by 9mm]) spaced 6-inches (150mm) on-center, such as "TB 125" by The TruFast Corp. or "Heavy Flat Bar" by Olympic.
- I. Stainless Steel Clamp: Stainless steel banding with worm-drive tightening, sized for application such as "Make-A-Clamp Kit" by Dynamic Fastener, 800/821-5448.
- J. Screen: Stainless steel wire screen with 1/2-inch (13mm) openings.

**2.05 FABRICATION - GENERAL:**

- A. Fabricate work in accordance with SMACNA Architectural Sheet Metal Manual and other recognized industry practices and reviewed shop drawings.
- B. Comply with material manufacturer's instructions and recommendations for forming material.
- C. Shop fabricate work to greatest extent possible. Fabricate inside and outside corners for metal edges, counterflashing, and coping caps. Fabricate corners with equal length legs, minimum 2 feet (1.2m).
- D. Fabricate for waterproof and weather resistant performance with expansion provisions for running work sufficient to permanently prevent leakage, damage, or deterioration of work. Form work to fit substrates.
- E. Make angle bends and folds for interlocking metal with full regard for expansion and contraction to avoid buckling or fullness in metal after installation.
- F. Form materials with straight lines, sharp angles, smooth curves, and true levels. Avoid tool marks, buckling, and oil canning.
- G. Fold back edges on concealed side of exposed edge to form hem.
- H. Lap joints 1-inch (25mm) minimum. Rivet and solder joints on parts that are to be permanently and rigidly assembled for copper, stainless, aluminum, and galvanized steel sheet metal. Install rivets, spaced 1-inch (25mm) on-center and apply solder to secure and seal exposed edge of sheet metal in a uniform continuous bead with smooth top finish. Clean residue upon completion of soldering process. Fabricate sheet metal assemblies so that adjoining sections are nested to achieve continuous metal-to-metal contact.
- I. Seams:
  - 1. Fabricate non-moving seams in sheet metal with flat-lock seams.
  - 2. Pre-finished Galvanized Steel: Seal pre-finished metal seams with rivets, spaced 1-inch (25mm) on-center, and silicone sealant, color to match metal finish.
  - 3. Metal Other than Aluminum: Tin edges to be seamed, form seams, and solder.
- J. Expansion Provisions: Where lapped or bayonet type expansion provisions in work cannot be used or would not be sufficiently waterproof or weatherproof, form expansion joints of intermeshing hooked flanges, not less than 1-inch deep, filled with mastic sealant concealed within joints.
- K. Sealant Joints: Where movable, non-expansion type joints are indicated or required for proper performance of work, form metal to provide for proper installation of elastomeric sealant in compliance with SMACNA standards.

**2.06 FABRICATED ITEMS:**

- A. Counter flashings: Minimum 24 gauge prefinished sheet metal formed in maximum 10 foot (3m) lengths fabricate "S"-shaped receiver to engage counter flashing a minimum of 1-inch; fabricate counter flashing with broken fascia of length to extend over top edge of base flashing a minimum of 4-inches with ½-inch hemmed drip edge. Utilize two piece configuration at walls.
- B. Wind Clips: Minimum 24 gauge prefinished sheet metal, 1-inch (25mm) wide, length to engage counter flashing a minimum of 1/2-inch (13mm).

**THE UNIVERSITY OF TEXAS HEALTH SCIENCE CENTER  
SCHOOL OF NURSING  
HOUSTON, TEXAS**

---

- C. Roof Penetration Base and Umbrella/Bonnet: Minimum 24 gauge stainless steel sheet metal, two-piece construction, fabricated in accordance with project drawings.
- D. Cleats/Clips:
  - 1. Concealed Cleats/Clips: Continuous strips, 22 gauge prefinished sheet metal, same fascia profile as adjacent metal item with 3/4-inch drip edge formed at a 30 degree angle with vertical wall.
  - 2. Exposed Cleats/Clips: 24 gauge prefinished sheet metal.
- E. Vent Hoods, Sleeves, Penetration Flashings, and Accessories: Minimum 24 gauge stainless steel sheet metal with 4-inch (100mm) flanges with rounded corners.
- F. Angle Termination Bar: 1-inch by 1-inch (25mm by 25mm) 24 gauge galvanized sheet metal.
- G. Vent Pipe: 2-1/2 pound lead with 4-inch flanges. Provide proper size to fold down inside of pipe a minimum of 1-inch (25mm).
- H. Door Threshold: 24 gauge stainless steel sheet metal.
- I. Penetration Flashing Pans: 24 gauge stainless steel sheet metal. Fabricate with 1/4-inch (6mm) hem at top edge and with 4-inch (100mm) flanges with rounded corners. Fabricate to provide installed minimum clear inside perimeter dimension of 2-inches (50mm) on each side of penetrating element and 6-inch height.
- J. Roof Drain: 4 pound lead, size 30-inch by 30-inch (750mm by 750mm).
- K. Equipment Straps: 1-inch wide 24 gauge stainless sheet metal straps.
- L. Pipe Box (Base, Hood, and Face Plate): 24 gauge stainless steel sheet metal. Base shall be 8-inches in height, 4-inch wide flanges with rounded corners and sized to provide minimum 2-inch clearance between pipes and box.
- M. Curb Cap Flashings: 24 gauge stainless steel sheet metal with 4-inch fascias.
- N. Scupper: Minimum 24 gauge stainless sheet metal with 4-inch wide flashing flanges.
- O. Collector Head and Downspouts: Minimum 24 gauge pre-finished sheet metal collector head with tapered bottom. Downspout shall be 5-inches (125mm) by 5-inches (125mm) with seam located on back of downspout. Downspout straps and gutter spacers shall be 1-inch wide double-hemmed stainless steel sheet metal. Provide downspout straps with rounded corners.
- P. Metal Edge: Minimum 24 gauge prefinished sheet metal formed in maximum 10 foot (3m) lengths, with 6-inch (150mm) wide cover plates of same profile, 4-inch (100mm) wide horizontal flange, and fascia length to extend beyond top of exterior wall finish a minimum of 1-inch and to match existing fabrication coverage.
- Q. Coping:
  - a. Shop-Fabricated Option: 24-gauge pre-finished sheet metal for 8-inch maximum width and 22-gauge for 8-inch to 12-inch width with 6-inch (150mm) wide back-up plates of same profile. Form 3/4-inch drips with 5/8-inch returns at 30-degree angle with vertical wall at bottom end of both interior and exterior fascias. Fabrication to meet specified ANSI/SPRI ES-1 requirements for 110 mph.
  - b. Pre-Manufactured Option: Pre-manufactured prefinished sheet metal coping of designated dimensions and meeting ANSI/SPRI ES-1 requirements for 110 mph with continuous cleat installed over sloped substrate such as "Sloped Formed Coping" by Hickman Engineered Systems, "One Coping" by Metal Era, or approved equal.



### **PART THREE - EXECUTION**

#### **3.01 EXAMINATION:**

- A. Verify that substrates are smooth and clean to extent needed for sheet metal work.
- B. Verify that reglets, nails, cants, and blocking to receive sheet metal are installed and free of concrete and soil.
- C. Do not start sheet metal work until conditions are satisfactory.

#### **3.02 INSTALLATION:**

- A. Install sheet metal with lines, arises, and angles sharp and true, and plane surfaces free from objectionable wave, warp, or buckle. Exposed edges of sheet metal shall be folded back to form 1/4-inch (6mm) hem on concealed side from view. Finished work shall be free from water retention and leakage under all weather conditions. Install prefabricated corners or transitions at changes in direction, elevation or plane, and at intersections. Locate field joints not less than 12-inches (300mm), nor more than 3 feet (1m) from actual corner. Laps for all metals, except for prefinished metal, shall be 1-inch (25mm) wide, fastened with rivets spaced 1-inch (25mm) on-center and soldered.
- B. Anchor units of work securely in place to prevent damage or distortion from wind or buckling. Provide for thermal expansion of metal units; conceal fasteners where possible; and set units true to line and level as indicated. Install work with laps, joints, and seams permanently watertight and weatherproof.
- C. Install fabricated sheet metal items in accordance with manufacturer's installation instructions and recommendations and with SMACNA Architectural Sheet Metal Manual.
- D. Separations: Provide for separation of metal from non-compatible metal or corrosive substrates by coating concealed surfaces with zinc chromate, bituminous coating, or other permanent separation at locations of contact as recommended by manufacturer or fabricator. Do not use materials incompatible with roofing system.
- E. Continuous Cleat: At exposed edges of gravel guards, fascias, cap flashings, and where required, attach continuous cleat at 6-inches (150mm) on-center with appropriate fasteners positioned on the vertical face and fastened into 2X blocking, and concrete/masonry substrate or metal or steel. At a distance of 10 feet (3m) from each direction of corner, install fasteners 3-inches (75mm) on-center. Install cleat so fascia extends a minimum of 1-inch (25mm) below top of exterior wall finish.
- F. Counter flashings:
  - 1. Install new counter flashings under equipment housing flanges and new receivers along rise or parapet walls to extend a minimum of 4-inches below top edge of base flashing. Secure counter flashing at 6-inches (150mm) on-center with self-tapping screws.

2. Secure 2-piece surface-mounted receiver and counter flashing assemblies along concrete substrates. Install sealant tape, Type C, between receiver and substrate. Secure receiver to substrate with termination bar and appropriate fasteners spaced 12-inches o.c. Install a continuous bead of sealant, Type B, along caulk trough/top edge of receiver and tool sealant to provide outward sloping finished surface. Secure counter flashing to receiver utilizing grommetted self-tapping screws spaced 6-inches (150mm) on-center. Install new receivers extending behind wall finish and secure vertical flange of receive 6-inches on-center and extend underlayment over vertical flange.
  3. Lap adjacent sections of receivers and counter flashings a minimum of 4-inches (100mm). Apply a continuous bead of sealant, Type A, in lap.
  4. Trim existing counter flashings to remain to receive new flashing.
  5. Secure new counter flashing to new receiver or trimmed existing flashing utilizing self-tapping screws spaced 6-inches (150mm) on-center.
  6. Install wind clips to termination bar spaced 24-inches (600mm) on-center.
  7. Fabricate the counter flashing to form an integral closure at terminations.
- G. Penetration Pans:
1. Install compressible fill insulation between penetrating element and deck.
  2. Prime top and bottom of flanges.
  3. Pop rivet and fully solder joints in pan and flanges.
  4. Install with flanges set in heat-softened APP membrane or uniform troweling of plastic roof cement on SBS membrane base ply, secure flange with appropriate fasteners spaced 6-inches on-center, staggered, and strip-in flanges.
  5. Fill penetration pan to within 1-inch (25mm) of top of pan with non-shrink grout. Fill remainder of pan with pourable sealer.
  6. Install umbrella/bonnet or hood.
- H. Roof Penetration Hoods and Umbrella/Bonnet:
1. Install watertight hood or umbrella/bonnet at penetration locations.
  2. Round or Pipe Penetrations:
    - a. Set umbrella/bonnet in sealant, Type A; utilize Type B sealant at heat sensitive areas.
    - b. Tighten draw band.
    - c. Seal top of umbrella/bonnet with sealant, Type A; utilize Type B sealant at heat sensitive units.
  3. Square Penetration:
    - a. Secure umbrella/bonnet to penetration with termination bar and self-drilling screws.
    - b. Set umbrella/bonnet in sealant, Type C.
    - c. Seal top of umbrella/bonnet with sealant, Type B.
- I. Primary Drains:
1. After membrane installation, prime bottom of lead flashing sheet and set in in heat-softened APP membrane or uniform bed of plastic roof cement on SBS membrane at specified locations.

2. Extend lead flashing into drain bowl or pipe a minimum of 2-inches (50mm) and over top of piping/bowl connection, if possible. Apply a continuous bead of sealant, Type A, at intersection of pipe and drain bowl.
  3. If drain bowl and pipe connection is contaminated with bituminous material, strip-in area with three-coursing of plastic roof cement and fabric.
  4. Prime top surface of lead flashing sheet to receive strip-in membrane.
- J. Pipe Box:
1. Pop rivet and fully solder joints and seams in base and hood.
  2. Prime top and bottom of flanges of base.
  3. Install with flanges set in heat-softened APP membrane or uniform bed of plastic roof cement on SBS membrane, secure flanges with appropriate fasteners spaced 6-inches on-center, staggered, and strip-in.
  4. Fill base with grout or spray foam to a height of 3/4 of the total pan height.
  5. Fill remaining height of base with pourable sealer.
  6. Install hood over base, securing to each side with self-tapping screws.
  7. Install face plate to cover box opening around pipe penetrations and apply sealant, Type B, around pipe configuration at face plate.
- K. Sanitary Vent Stacks:
1. Prime top and bottom flanges of lead flashing sleeve. Set flange in heat-softened APP membrane or uniform troweling of plastic roof cement on SBS membrane. Prime top side of flange to receive strip-in membrane.
  2. Fold lead sleeve down inside pipe a minimum of 1-inch (25mm). Apply a continuous bead of sealant on inside of pipe prior to folding lead sleeve.
  3. After installation of lead flashing, install screen over top of vent pipe and secure with adjustable strap.
- L. Equipment Straps:
1. After equipment is installed on top of curbs, install sheet metal straps extending over top of equipment and secured into side of support curb with grommetted fasteners.
  2. Install one strap on each side of equipment.
- M. Metal Edge:
1. Extend modified bitumen sheet to minimum 1-inch (25mm) below bottom edge of nailer or top of exterior wall finish.
  2. Prime bottom side of metal edge and set in bed of plastic roof cement on SBS base ply or heat softened APP membrane base ply and lock to cleat. Install adjacent sections of metal edge with approximate 1/4-inch (6mm) space between sections.
  3. Secure horizontal flange of metal edge to wood nailer with appropriate fasteners spaced 3-inches (75mm) on-center, staggered.
  4. Install covers at joints, locking onto cleat. Embed flange into plastic roof cement and install continuous beads of sealant, Type B, placed on each side of joint on fascia. Fasten joint cover with appropriate fastener centered in joint.
  5. Prime top metal surface of flange to receive strip-in membrane.

- N. Scupper/Collector Head/Downspout:
1. After field membrane is installed, install metal scupper insert into wall opening. Set scupper in bed of plastic roof cement or heat-softened membrane and secure flanges of scupper to wall and deck with appropriate fasteners.
  2. Strip-in flanges of scupper with appropriate flashing plies.
  3. Install sealant, Type A, around exterior opening of scupper between metal insert and wall.
  4. Attach collector head to scupper insert. Secure collector head to scupper insert and wall and apply sealant around perimeter.
  5. Install new downspouts plumb and level, attached to columns or wall with straps located at top and bottom of downspout and 10 feet (3m) on-center, maximum. Extend downspouts into existing and/or new inlet or pipe. Provide "square-to-round" sheet metal transition to connect downspout to opening of pipe/inlet.
  6. Install splash block under discharge port of downspouts. Install splash block over a protection pad for downspouts located at roof level.
- O. Equipment Curb Caps:
1. Install new wood nailers on top of curb to provide substrate to receive cap flashing.
  2. Install and adhere underlayment/modified bitumen flashing over top of curb extending a minimum 4-inches below top of curb and overlapping top edge of base flashing.
  3. Install metal cap flashing over curb. Install appropriate fasteners through the fascia spaced 12-inches on-center.
  4. Reinstall equipment on top of cap flashing on top of vibration isolator pads.
- P. Door Threshold:
1. At existing roof access doors, install sheet metal threshold over substrate and secure with flat-head countersunk screws.
- Q. Coping:
1. Install new 2X wood nailers and/or 2X wood nailers and plywood to provide substrate on top of wall to have a resulting positive slope (minimum 1-inch per foot) toward roof.
  2. Install and adhere underlayment or flashing membrane over the wood substrate extending a minimum of 1-inch below top of wall system. Lap ends minimum of 3-inches (75mm) and secure membrane in place on exterior vertical face.
  3. Install metal coping segments allowing 1/2-inch (13mm) spaces between segments. Lock coping onto cleat and install appropriate fasteners through the interior fascia spaced 24-inches (600mm) on-center in enlarged holes.
  4. Install back-up plates centered under butt joints at adjoining sections of coping and set in continuous beads of sealant, Type B, placed approximately 1-inch (25mm) from cover edges.
  5. Install appropriate fastener through neoprene washer and back-up plate between coping segments. Apply bead of sealant, color to match sheet metal, in butt joint tooled to match surface of adjacent coping sections.

6. Install cap bead of sealant, Type B, over sealed/riveted lap seam in coping at corners. Apply tape on coping to provide straight edges of tooled cap bead. Remove tape upon completion of tooling.
7. Install pre-manufactured/pre-engineered coping systems in accordance with manufacturer's installation guidelines. Provide and install pre-fabricated corners and end caps/terminations.

**3.03 CLEANING:**

- A. Remove flux and residual acid immediately by neutralizing with baking soda and washing with clean water. Leave work clean and free of stains, scrap, and debris.
- B. Clean exposed metal surfaces, removing substances which might cause corrosion of metal or deterioration/damage of finishes. Paint (color to match) areas of prefinished metal where finish is damaged. Replace sheet metal items when damaged finish can not be repaired to an acceptable condition.
- C. Prime soldered area of phosphatized metal after cleaning to prevent rusting.
- D. Paint metal flashings that have been soiled. Use medium nap roller to apply paint to surfaces to achieve monolithic finished color.

**END OF SECTION 07 62 00**

**SECTION 26 41 00**

**LIGHTNING PROTECTION SYSTEM**

**PART ONE - GENERAL**

**1.01 SECTION INCLUDES:**

- A. Removal and reinstallation of existing lightning protection system.
- B. Furnish all labor, materials, and items of service required for completion of a functional and unobtrusive lightning protection system.
- C. System furnished shall be the standard product of manufacturer's regularly engaged in the production of lightning protection equipment.
- D. Lightning protection system shall be as approved by Owner's Representative.
- E. Cooperate with the roofing contractor and roofing material manufacturer to maintain roofing warranties.

**1.02 RELATED SECTIONS:**

- A. 02 07 20 - Minor Demolition and Renovation Work.
- B. 07 52 50 - Modified Bitumen Membrane Roofing
- C. 07 62 00 - Sheet Metal Flashing and Trim

**1.03 STANDARDS:**

- A. Lightning Protection Institute Installation Standard, LPI 175.
- B. Underwriters Laboratories, Inc. Installation Requirement, UL96A.
- C. National Fire Protection Association Lightning Protection Code, NFPA78.
- D. National Electrical Code (NEC).

**1.04 SUBMITTALS:**

- A. Product Data: Submit manufacturer's data sheets for each product to be used.
- B. Shop Drawings:
  - 1. Submit shop drawings.
  - 2. Prepare scaled roof plan locating and identifying all required details.
  - 3. Show type, size, and location of all grounding, down conductors, through roof/through wall assemblies, and roof conductors.
- C. Certificates:
  - 1. Underwriters Laboratories Inc. Master Label.
  - 2. Lightning Protection Institute Certification.
  - 3. Field-applied certification plates.

**1.05 QUALITY ASSURANCE:**

- A. Applicator:
  - 1. Employees Certified Master Installers.
  - 2. Company is UL listed.
  - 3. Member of Lightning Protection Institute.

- B. Regulatory Requirements: The lightning protection system shall conform to the requirements of the LPI, UL, NFPA, and NEC.
- C. Inspection: Contractor shall apply to Underwriters Laboratories Inc. for inspection and certification.

## **PART TWO - PRODUCTS**

### **2.01 MATERIALS:**

- A. Copper and bronze and sized, weighted, and constructed to suit pre-application.
- B. Bolt type connectors and splicers shall be utilized.
- C. All mounting hardware shall be stainless steel.
- D. Ground rods shall be stainless steel of appropriate diameter.
- E. Air Terminals: Blunt end copper or aluminum units.
- F. Braided Cable: Copper or aluminum braided cable.
- G. Sealant Adhesive: Non-slump moisture curing structural sealant, gray in color, such as "M-1 Structural Sealant" by ChemLink, Inc.

## **PART THREE - EXECUTION**

### **3.01 GENERAL INSTALLATION:**

- A. The installation shall be accomplished by an experienced installation company that is UL listed, a member of the Lightning Protection Institute, United Lightning Protection Association qualified, and an employer of Certified Master Installers of lightning protection systems.
- B. A Certified Master Installer shall directly supervise the work.
- C. All equipment shall be installed in a neat, workmanlike manner.
- D. The system shall consist of a complete conductor network at the roof and include air terminals, connectors, splicers, bonds, copper downleads, and proper ground terminals.
- E. Lightning Protection System:
  - 1. Temporarily disconnect, remove, and salvage the lightning protection system including, but not limited to, cables, holders, clamps, and clips.
  - 2. Reinstall the lightning protection system so that, upon completion, system can be re-certified by UL.
  - 3. Install equipment in a neat, workmanlike manner.
  - 4. System shall consist of a complete conductor network at the roof and include air terminals, connectors, splicers, bonds, and other associated hardware.
  - 5. Secure bases of air terminals and cable holders to inside vertical face of coping or parapet walls with grommetted screws. Install cut section of EPDM rubber or rubber gasket between coping and secured hardware.
  - 6. Set air terminal bases and metal cable holders in bed of sealant adhesive on top of cut section of modified bitumen protection pad installed on top of capsheet.
  - 7. Install aluminum cables where cable is to be in full contact with roof membrane.

**3.02 COORDINATION:**

- A. The lightning protection installer will work with other trades to ensure a correct, neat, and unobtrusive installation.
- B. It shall be the responsibility of the lightning protection installer to assure a sound bond to the main water service and to assure interconnection with other ground systems.

**3.03 CLEANING:**

- A. Remove trash, debris, equipment, and parts from the jobsite.
- B. Clean exposed metal surfaces, removing substances that might cause corrosion of metal components.

**END OF SECTION 26 41 00**



# UT HEALTH THE UNIVERSITY OF TEXAS HEALTH SCIENCE CENTER OF HOUSTON



## ROOF REPLACEMENT

for  
SCHOOL OF NURSING  
6901 BERTNER  
HOUSTON, TX

PREPARED BY  
PRICE CONSULTING, INCORPORATED  
211 HIGHLAND CROSS, SUITE 220  
HOUSTON, TEXAS 77073  
(281) 209-1724  
TX P.E. FIRM F-3814

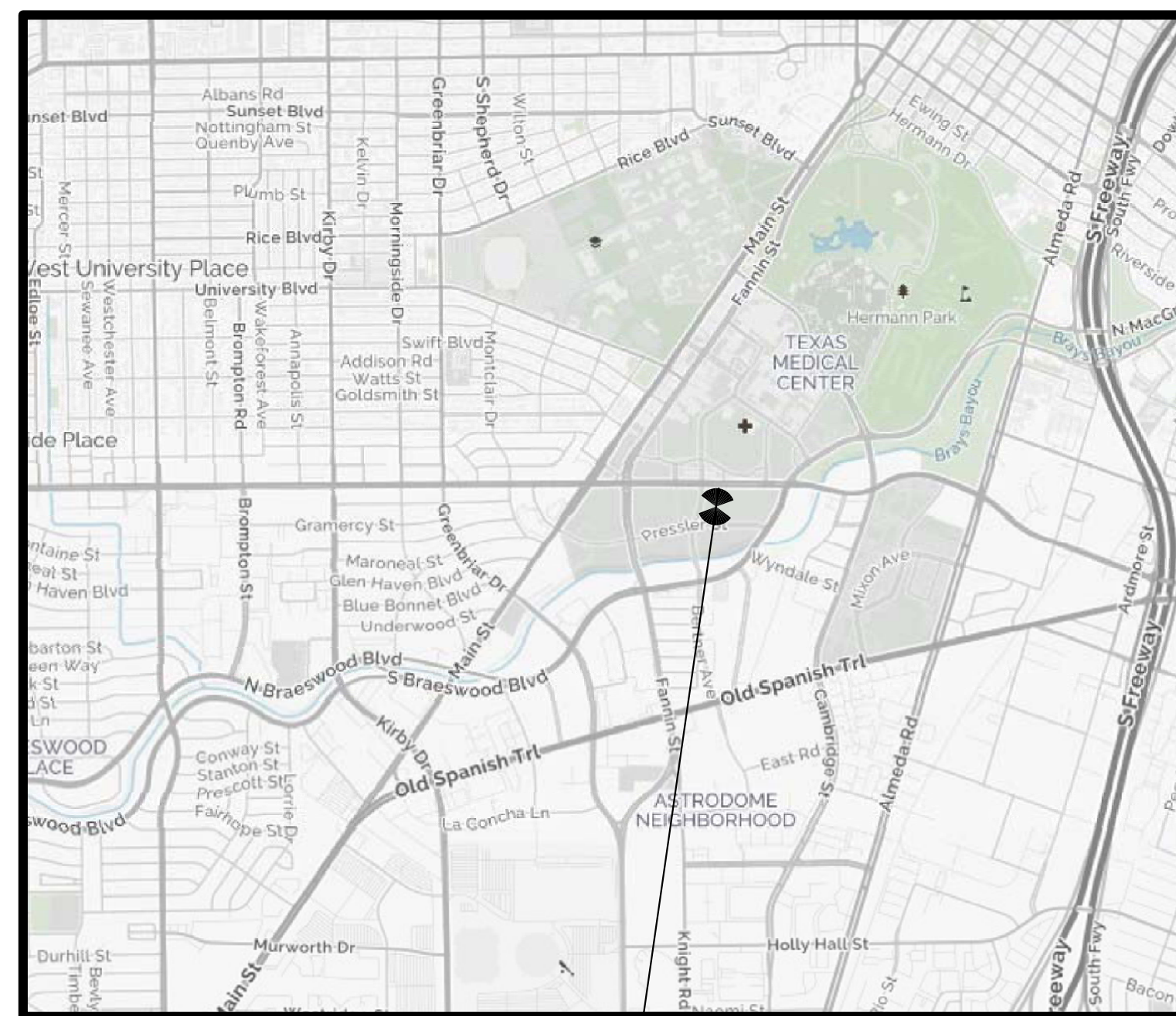

PROJECT SITE

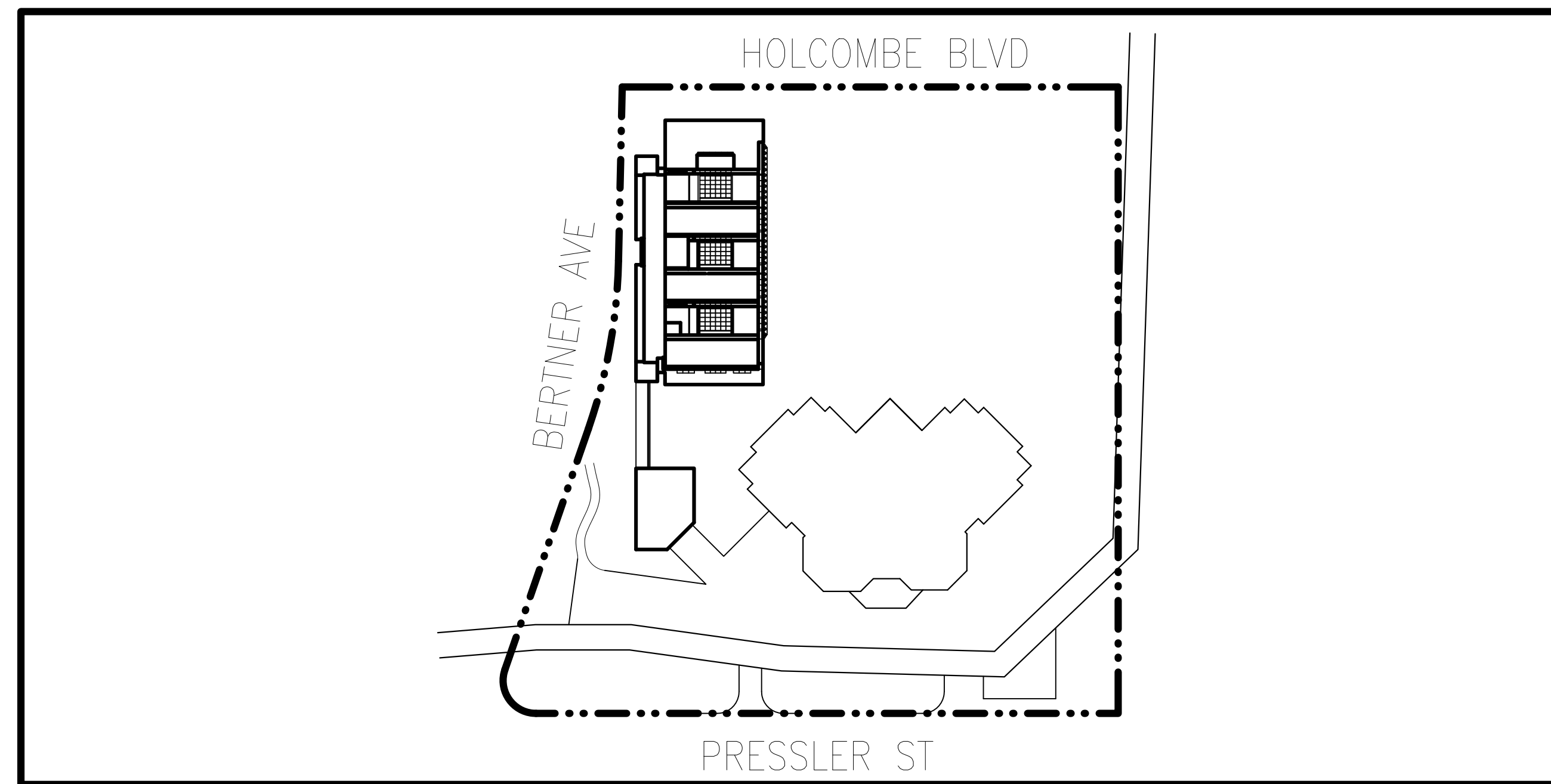

SITE PLAN

## INDEX TO DRAWINGS

- R1.00 COVER SHEET
- R1.01 GENERAL NOTES
- R2.00 EXISTING ROOF PLAN
- R2.01 ROOF PHASING PLAN
- R2.02 OVERALL NEW ROOF PLAN
- R2.03 PARTIAL NEW ROOF PLAN: AREA "A"
- R2.04 PARTIAL NEW ROOF PLAN: AREA "B"
- R2.05 PARTIAL NEW ROOF PLAN: ALT. BID NO. 2
- R5.00 DETAILS
- R5.01 DETAILS
- R5.02 DETAILS

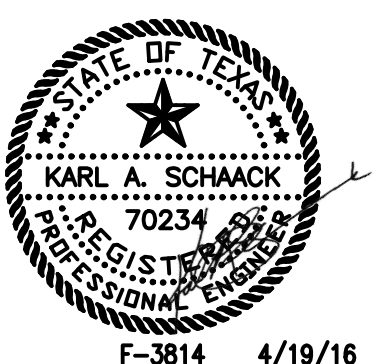

F-3814 4/19/16

**PRICE CONSULTING, INC.**  
PRICE CONSULTING, INC.  
211 HIGHLAND CROSS, SUITE 220  
HOUSTON, TEXAS 77073  
PHONE: (281)209-1724 FAX: (281)209-2724

PROJECT:  
UTHSC - SCHOOL OF NURSING  
6901 BERTNER AVE  
HOUSTON, TX

OWNER/CLIENT:  
UT HEALTH SCIENCE CENTER AT HOUSTON  
7000 FANNIN, UCT M125  
HOUSTON, TEXAS 77030

REVISIONS		
NO.	DATE	BY

COVER SHEET  
PCI PROJECT NO.: 11204.15  
PCI FILE NAME: CS1  
SCALE: AS NOTED



NORTH

DWN.BY: DATE:  
ESG 04/19/16  
SHEET:  
R1.00

# GENERAL NOTES: ROOF REPLACEMENT -

- 1) ALL DIMENSIONS, EQUIPMENT, AND PENETRATION LOCATIONS PRESENTED ON THE DRAWINGS ARE CONSIDERED APPROXIMATE. CONTRACTOR SHALL FIELD VERIFY ALL CONDITIONS.
- 2) THESE DRAWINGS AND DETAILS ACCOMPANY SPECIFICATIONS AND DOCUMENTS THAT COMPRISE A PROJECT MANUAL.
- 3) DETAILS ARE DESIGNATED AT REPRESENTATIVE LOCATIONS. EACH LOCATION AND SIMILAR CONDITIONS ARE TO BE TREATED ACCORDINGLY.  
  
TYPICAL DETAIL DESIGNATION: 

1	—	DETAIL NUMBER
RP1	—	SHEET NUMBER
- 4) UNLESS INDICATED BY THE TERM "EXISTING", ITEMS PRESENTED ON DETAIL DRAWINGS ARE CONSIDERED TO BE NEW AND FURNISHED BY CONTRACTOR.
- 5) EXISTING ROOF CONSTRUCTION OBSERVED AT PCI CORE LOCATIONS CONSISTS OF THE FOLLOWING: :  
  
1) TPO SINGLE-PLY MEMBRANE, FIBERBOARD INSULATION, POLYISOCYANURATE INSULATION AND EITHER CONCRETE ON FLUTED STEEL DECK.
- 6) REMOVE EXISTING ROOFING, INSULATION, AND SHEET METAL FLASHINGS DOWN TO DECK.
- 7) EQUIPMENT SITTING ON WOOD SLEEPERS OR EQUIPMENT PADS TO BE TEMPORARILY DISCONNECTED AND LIFTED AND RE-SET ON NEW CURBS ANCHORED TO DECK AND STRAPS INSTALLED OVER EQUIPMENT ANCHORED TO CURBS.
- 8) INSTALL S.S. SHEET METAL STRAPS, ONE PER SIDE, TO SECURE EQUIPMENT HOODS TO CURBS.
- 9) TYPICAL NEW ROOF CONSTRUCTION IS AS FOLLOWS:  
  
POLYISOCYANURATE INSULATION COMPLYING WITH IBC SECTION 1508 AND TABLE 1508.2.; TO ACHIEVE MINIMUM TOTAL R-VALUE OF R-20., WITH ROOF COVER BOARD, AND A TWO-PLY MODIFIED BITUMEN ROOF MEMBRANE CONSISTING ONE PLY OF SMOOTH SURFACED BASE PLY & ONE PLY OF CAP SHEET WITH WHITE REFLECTIVE SURFACING COMPLYING WITH IBC SECTION 1507.11; SECTION 1505.2: CLASS "A" FIRE CLASIFICATION AND TO HAVE MINIMUM SOLAR REFLECTANCE OF 0.70 AS TESTED PER ASTM C1549; E903, E1175, OR E1918 AND A MINIMUM THERMAL EMITTANCE OF 0.75 AS TESTED PER ASTM C835, C1371, OR E408.
- 10) RAISE OR LOWER ALL EQUIPMENT, UTILITY LINES, PENETRATIONS, PIPING, ETC. AS REQUIRED FOR INSTALLATION OF THE NEW ROOF SYSTEM. PROVIDE NECESSARY DISCONNECT/RECONNECT, EXTENSIONS AND MISC. COMPONENTS.
- 11) PROVIDE LIQUID FLASHING SYSTEM FOR STEEL PIPES, ANGLES, TUBE POSTS & OTHER SIMILAR PENETRATIONS THROUGH THE ROOF SYSTEM.
- 12) INSTALL WALK PADS AT ROOF ACCESS POINTS, AROUND SERVICEABLE EQUIPMENT AND OTHER HIGHLY TRAFFICKED AREAS.
- 13) PROVIDE NEW WOOD BLOCKING/NAILERS AS DESIGNATED ON DRAWINGS. BLOCKING/NAILERS, &/OR COMBINATION WITH PLYWOOD/OSB SHEATHING TO MATCH THICKNESS OF INSULATION AT RESPECTIVE LOCATIONS, AND WIDTH TO EXTEND BEYOND EDGE OF METAL FLANGE (MIN. 1-INCH) WHERE APPLICABLE.

- 14) WATER TEST ROOF DRAINS; WIRE BRUSH; & PAINT CLAMP RINGS & STRAINERS; SECURE CLAMP RINGS W/SS BOLTS, WASHERS, NUTS; REPLACE BROKEN/DAMAGED COMPONENTS.
- 15) INSTALL NEW ROOF SYSTEM TESTED TO MEET SPECIFIED WIND UPLIFT PRESSURES AS FOLLOWS:

<b>ROOF SYSTEM WIND UPLIFT CRITERIA:</b>		WIND SPEED: 110MPH IMPORTANCE FACTOR: 1.15 EXPOSURE: B BUILDING CATEGORY: ENCLOSED SAFETY FACTOR: 2.0
<b>MAIN/PENTHOUSE</b>		
<b>FIELD</b>	<b>105 PSF</b>	
<b>PERIMETER (8' WIDE)</b>	<b>165 PSF</b>	
<b>CORNER (8'X8')</b>	<b>225 PSF</b>	

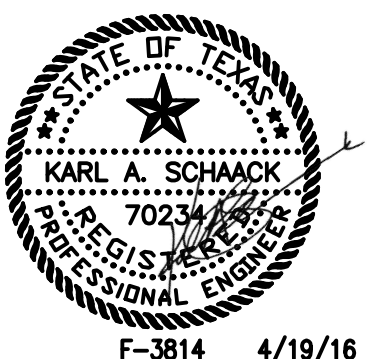

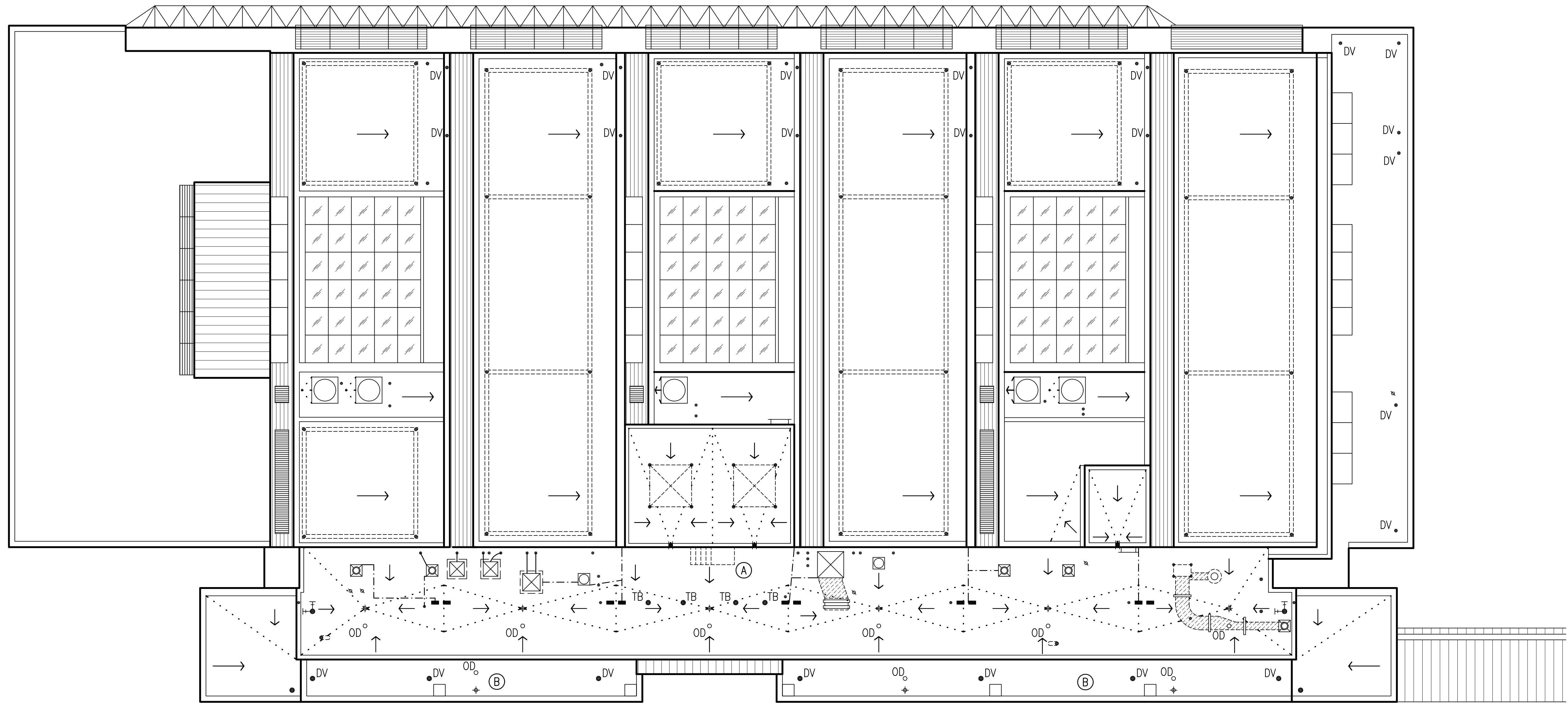

EXISTING ROOF PLAN:  
SCALE: 1"=20'-0" (1:1117); 1"=10'-0" (22:334)

LEGEND			
○ <sup>OD</sup>	OVERFLOW DRAIN	△	WALL DRAIN
⊕	ROOF DRAIN	⊕	SUMPED DRAIN
⊗	PLUMBING VENT	⊙	HEAT EXHAUST
⊖	POWER VENT	⊗	CURBED HEAT EXHAUST
⊗	CURBED VENT STACK	⊕	GRAVITY VENT
⊗	TURBINE VENT	⊙	GRAVITY VENT
⊗	CURBED TURBINE VENT	⊖	MOISTURE RELIEF VENT
●	ROUND PENETRATION	⊖	GOOSENECK PENETRATION
⊖	ABANDONED PENETRATION	⊖	PIPE BOX
⊕	PIPING ON HANGERS	—	EXPANSION JOINT
⊕	PIPING ON WOOD BLOCKING	—	ROOF-TO-WALL EXPANSION JOINT
⊕	PIPING ON SUPPORTS	—	METAL EDGE
—	PARAPET	—	DOWNSPOUT AND GUTTER
— <sup>CD</sup>	CONDENSATION DRAIN LINE	— <sup>MS</sup>	MECHANICAL SCREEN
— <sup>E</sup>	ELECTRICAL CONDUIT	— <sup>W</sup>	CHILL / HOT WATER
— <sup>G</sup>	GAS LINE	⊕ <sup>AT</sup>	AIR TERMINAL
■	PITCH PAN	⊕ <sup>LP</sup>	THROUGH-ROOF CONNECTION
⊕	DUCT PENETRATION	⊕	CURBED DUCT PENETRATION
⊕	EQUIPMENT CURB	⊕	DUCT WITH DUCT SUPPORT
⊕	VENT / INTAKE	⊕	THROUGH-WALL SCUPPER
⊕	GRAVITY VENT	⊕	THROUGH-EDGE SCUPPER
⊕	SCUPPER WITH COLLECTOR HEAD	⊕	EQUIPMENT ON SLEEPERS
⊕	EQUIPMENT ON SUPPORTS	⊕	EQUIPMENT ON CURBS
⊕	EQUIPMENT ON PITCH PANS	⊕	ROOF HATCH
⊕	SMOKE HATCH	⊕	SKYLIGHT
⊕	SATELLITE DISH	⊕	STRUCTURAL SKYLIGHT
⊕	ROOF-MOUNTED LADDER	⊕	STRUCTURAL SKYLIGHT
⊕	CAGED LADDER	⊕	CHIMNEY
⊕	WALL-MOUNTED LADDER	⊕	ROUND GOOSENECK
⊕	WALKPAD	⊕	SQUARE GOOSENECK
⊕	SPLASHBLOCK	⊕	RISE-WALL
⊕	12" WALL THICKNESS INDICATOR	⊕	DIRECTION OF SLOPE
⊕	2" WALL HEIGHT INDICATOR	⊕	RIDGE / VALLEY
⊕	DOOR ACCESS	⊕	GUY WIRE ANCHOR
⊕	LIGHT	⊕	TILE ROOF
⊕	SHINGLE ROOF	⊕	METAL ROOF
⊕	ANTENNA	⊕	COLUMN
⊕ <sup>A2</sup>	AREA IDENTIFICATION	⊕	SUSPECTED WET AREA
⊕ <sup>X</sup>	CORE LOCATION	⊕	PHOTO LOCATION
⊕ <sup>L</sup>	LEAK LOCATION	⊕	PROBE LOCATION
⊕ <sup>XX</sup>	INFRARED I.D.	⊕	TIE-BACK
⊕	TEST LOCATION	⊕	

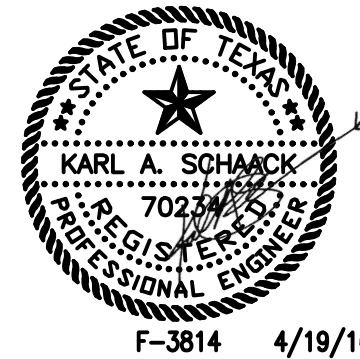

F-3814 4/19/16

**PRICE CONSULTING, INC.**  
PRICE CONSULTING, INC.  
211 HIGHLAND CROSS, SUITE 220  
HOUSTON, TEXAS 77073  
PHONE: (281)209-1724 FAX: (281)209-2724

PROJECT:  
UTHSC - SCHOOL OF NURSING  
6901 BERTNER AVE  
HOUSTON, TX

OWNER/CLIENT:  
UT HEALTH SCIENCE CENTER AT HOUSTON  
7000 FANNIN, UCT M125  
HOUSTON, TEXAS 77030

REVISIONS		
NO.	DATE	BY

ROOF PLAN  
PCI PROJECT NO.: 11204.15  
PCI FILE NAME: R2.00-R2.05  
SCALE: AS NOTED

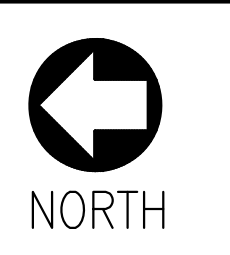

DWN.BY: DATE:  
ESG 04/19/16  
SHEET:  
R2.00



LEGEND			
○ <sup>OD</sup>	OVERFLOW DRAIN	△	WALL DRAIN
⊕	ROOF DRAIN	⊕	SUMPED DRAIN
⊗	PLUMBING VENT	⊙	HEAT EXHAUST
⊖	POWER VENT	⊖	CURBED HEAT EXHAUST
⊗	CURBED VENT STACK	⊕	GRAVITY VENT
⊗	TURBINE VENT	⊙	GRAVITY VENT
⊗	CURBED TURBINE VENT	⊖	MOISTURE RELIEF VENT
●	ROUND PENETRATION	⊖	GOOSENECK PENETRATION
⊖	ABANDONED PENETRATION	⊖	PIPE BOX
⊕	PIPING ON HANGERS	—	EXPANSION JOINT
⊕	PIPING ON WOOD BLOCKING	—	ROOF-TO-WALL EXPANSION JOINT
⊕	PIPING ON SUPPORTS	—	METAL EDGE
—	PARAPET	—	DOWNSPOUT AND GUTTER
— <sup>CD</sup>	CONDENSATION DRAIN LINE	— <sup>MS</sup>	MECHANICAL SCREEN
— <sup>E</sup>	ELECTRICAL CONDUIT	— <sup>W</sup>	CHILL / HOT WATER
— <sup>G</sup>	GAS LINE	⊕ <sup>AT</sup>	AIR TERMINAL
■	PITCH PAN	⊕ <sup>LP</sup>	THROUGH-ROOF CONNECTION
⊖	DUCT PENETRATION	⊖	CURBED DUCT PENETRATION
⊖	EQUIPMENT CURB	⊕	DUCT WITH DUCT SUPPORT
⊖	VENT / INTAKE	⊕	THROUGH-WALL SCUPPER
⊖	GRAVITY VENT	⊕	THROUGH-EDGE SCUPPER
⊕	SCUPPER WITH COLLECTOR HEAD	⊕	EQUIPMENT ON SLEEPERS
⊕	EQUIPMENT ON SUPPORTS	⊕	EQUIPMENT ON CURBS
⊕	EQUIPMENT ON PITCH PANS	⊕	ROOF HATCH
⊕	SMOKE HATCH	⊕	SKYLIGHT
⊕	SATELLITE DISH	⊕	STRUCTURAL SKYLIGHT
⊕	ROOF-MOUNTED LADDER	⊕	STRUCTURAL SKYLIGHT
⊕	CAGED LADDER	⊕	CHIMNEY
⊕	WALL-MOUNTED LADDER	⊕	ROUND GOOSENECK
⊕	WALKPAD	⊕	SQUARE GOOSENECK
⊕	SPLASHBLOCK	⊕	RISE-WALL
⊕	12" WALL THICKNESS INDICATOR	⊕	DIRECTION OF SLOPE
⊕	2" WALL HEIGHT INDICATOR	⊕	RIDGE / VALLEY
⊕	DOOR ACCESS	⊕	GUY WIRE ANCHOR
⊕	LIGHT	⊕	TILE ROOF
⊕	SHINGLE ROOF	⊕	METAL ROOF
⊕	ANTENNA	⊕	COLUMN
⊕ <sup>A2</sup>	AREA IDENTIFICATION	⊕	SUSPECTED WET AREA
⊕ <sup>X</sup>	CORE LOCATION	⊕ <sup>XX</sup>	PHOTO LOCATION
⊕ <sup>L</sup>	LEAK LOCATION	⊕ <sup>XX</sup>	PROBE LOCATION
⊕ <sup>XX</sup>	INFRARED I.D.	⊕	TIE-BACK
⊕	TEST LOCATION		

ROOF PHASING PLAN  
SCALE: 1"=20'-0" (11'117"), 1"=10'-0" (22'x34")

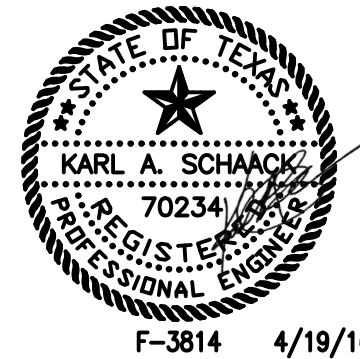

**PRICE CONSULTING, INC.**  
PRICE CONSULTING, INC.  
211 HIGHLAND CROSS, SUITE 220  
HOUSTON, TEXAS 77073  
PHONE: (281)209-1724 FAX: (281)209-2724

PROJECT:  
UTHSC - SCHOOL OF NURSING  
6901 BERTNER AVE  
HOUSTON, TX

OWNER/CLIENT:  
UT HEALTH SCIENCE CENTER AT HOUSTON  
7000 FANNIN, UCT M125  
HOUSTON, TEXAS 77030

REVISIONS		
NO.	DATE	BY

ROOF PLAN  
PCI PROJECT NO.: 11204.15  
PCI FILE NAME: R2.00-R2.05  
SCALE: AS NOTED

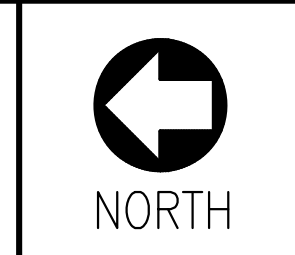

DWN.BY: DATE:  
ESG 04/19/16  
SHEET:  
R2.01

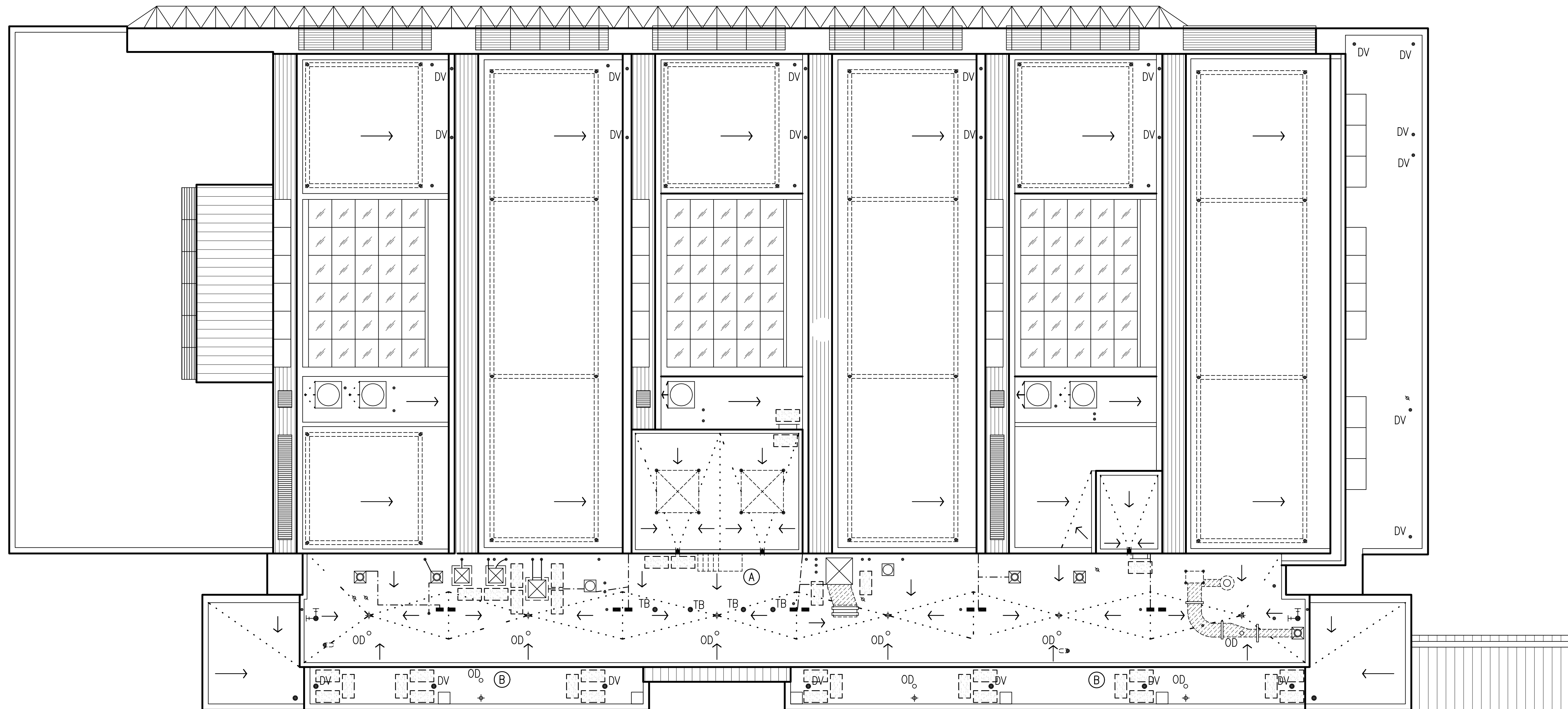

LEGEND			
○ <sup>OD</sup>	OVERFLOW DRAIN	△	WALL DRAIN
⊕	ROOF DRAIN	⊕	SUMPED DRAIN
⊗	PLUMBING VENT	⊙	HEAT EXHAUST
⊠	POWER VENT	⊠	CURBED HEAT EXHAUST
⊠	CURBED VENT STACK	⊕	GRAVITY VENT
⊗	TURBINE VENT	⊙	GRAVITY VENT
⊠	CURBED TURBINE VENT	⊙	MOISTURE RELIEF VENT
●	ROUND PENETRATION	⊙	GOOSENECK PENETRATION
⊠	ABANDONED PENETRATION	⊠	PIPE BOX
⊕	PIPING ON HANGERS	—	EXPANSION JOINT
⊕	PIPING ON WOOD BLOCKING	—	ROOF-TO-WALL EXPANSION JOINT
⊕	PIPING ON SUPPORTS	—	METAL EDGE
—	PARAPET	—	DOWNSPOUT AND GUTTER
—	CONDENSATION DRAIN LINE	—	MS— MECHANICAL SCREEN
—	ELECTRICAL CONDUIT	—	w— CHILL / HOT WATER
—	GAS LINE	⊕	AIR TERMINAL
■	PITCH PAN	⊕	THROUGH-ROOF CONNECTION
⊠	DUCT PENETRATION	⊠	CURBED DUCT PENETRATION
⊠	EQUIPMENT CURB	⊕	DUCT WITH DUCT SUPPORT
⊠	VENT / INTAKE	⊕	THROUGH-WALL SCUPPER
⊠	GRAVITY VENT	⊕	THROUGH-EDGE SCUPPER
⊕	SCUPPER WITH COLLECTOR HEAD	⊕	EQUIPMENT ON SLEEPERS
⊕	EQUIPMENT ON SUPPORTS	⊕	EQUIPMENT ON CURBS
⊕	EQUIPMENT ON PITCH PANS	⊕	ROOF HATCH
⊕	SMOKE HATCH	⊕	SKYLIGHT
⊕	SATELLITE DISH	⊕	STRUCTURAL SKYLIGHT
⊕	ROOF-MOUNTED LADDER	⊕	STRUCTURAL SKYLIGHT
⊕	CAGED LADDER	⊕	CHIMNEY
⊕	WALL-MOUNTED LADDER	⊕	ROUND GOOSENECK
⊕	WALKPAD	⊕	SQUARE GOOSENECK
⊕	SPLASHBLOCK	⊕	RISE-WALL
12"	WALL THICKNESS INDICATOR	⊕	DIRECTION OF SLOPE
2"	WALL HEIGHT INDICATOR	⊕	RIDGE / VALLEY
△	DOOR ACCESS	⊕	GUY WIRE ANCHOR
⊕	LIGHT	⊕	TILE ROOF
⊕	SHINGLE ROOF	⊕	METAL ROOF
⊕	ANTENNA	⊕	COLUMN
A2	AREA IDENTIFICATION	⊕	SUSPECTED WET AREA
⊕	CORE LOCATION	⊕	PHOTO LOCATION
⊕	LEAK LOCATION	⊕	PROBE LOCATION
⊕	INFRARED I.D.	⊕	TIE-BACK
⊕	TEST LOCATION		

OVERALL NEW ROOF PLAN  
SCALE: 1"=20'-0"(11x17), 1"=10'-0"(22x34)

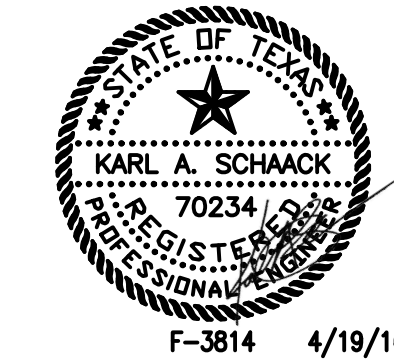

**PRICE CONSULTING, INC.**  
PRICE CONSULTING, INC.  
211 HIGHLAND CROSS, SUITE 220  
HOUSTON, TEXAS 77073  
PHONE: (281)209-1724 FAX: (281)209-2724

PROJECT:  
UTHSC - SCHOOL OF NURSING  
6901 BERTNER AVE  
HOUSTON, TX

OWNER/CLIENT:  
UT HEALTH SCIENCE CENTER AT HOUSTON  
7000 FANNIN, UCT M125  
HOUSTON, TEXAS 77030

REVISIONS		
NO.	DATE	BY

ROOF PLAN  
PCI PROJECT NO.: 11204.15  
PCI FILE NAME: R2.00-R2.05  
SCALE: AS NOTED



DWN.BY: DATE:  
ESG 04/19/16  
SHEET:  
R2.02

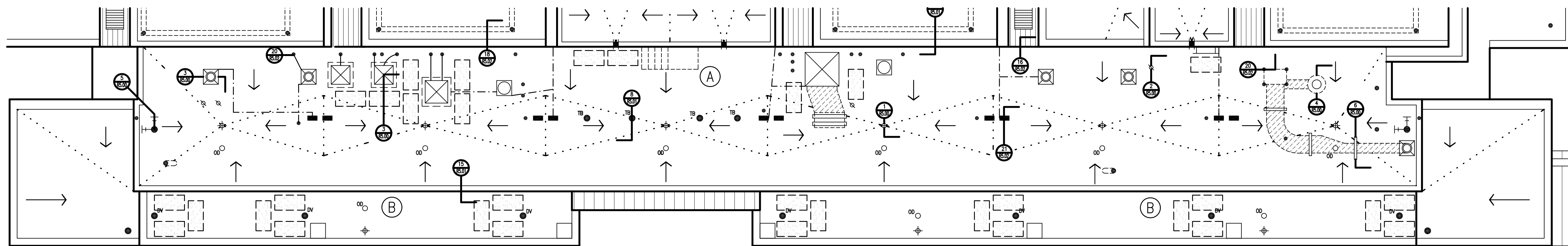

LEGEND			
○ <sup>OD</sup>	OVERFLOW DRAIN	△	WALL DRAIN
⊕	ROOF DRAIN	⊕	SUMPED DRAIN
⊗	PLUMBING VENT	⊙	HEAT EXHAUST
⊠	POWER VENT	⊠	CURBED HEAT EXHAUST
⊠	CURBED VENT STACK	⊕	GRAVITY VENT
⊠	TURBINE VENT	⊙	GRAVITY VENT
⊠	CURBED TURBINE VENT	⊙	MOISTURE RELIEF VENT
●	ROUND PENETRATION	⊙	GOOSENECK PENETRATION
⊠	ABANDONED PENETRATION	⊠	PIPE BOX
⊕	PIPING ON HANGERS	---	EXPANSION JOINT
⊕	PIPING ON WOOD BLOCKING	---	ROOF-TO-WALL EXPANSION JOINT
⊕	PIPING ON SUPPORTS	---	METAL EDGE
---	PARAPET	---	DOWNSPOUT AND GUTTER
-CD-	CONDENSATION DRAIN LINE	-MS-	MECHANICAL SCREEN
-E-	ELECTRICAL CONDUIT	-W-	CHILL / HOT WATER
-G-	GAS LINE	⊕	AIR TERMINAL
■	PITCH PAN	⊕	THROUGH-ROOF CONNECTION
⊠	DUCT PENETRATION	⊠	CURBED DUCT PENETRATION
⊠	EQUIPMENT CURB	⊕	DUCT WITH DUCT SUPPORT
⊠	VENT / INTAKE	⊕	THROUGH-WALL SCUPPER
⊠	GRAVITY VENT	⊕	THROUGH-EDGE SCUPPER
⊕	SCUPPER WITH COLLECTOR HEAD	⊕	EQUIPMENT ON SLEEPERS
⊕	EQUIPMENT ON SUPPORTS	⊕	EQUIPMENT ON CURBS
⊕	EQUIPMENT ON PITCH PANS	⊕	ROOF HATCH
⊕	SMOKE HATCH	⊕	SKYLIGHT
⊕	SATELLITE DISH	⊕	STRUCTURAL SKYLIGHT
⊕	ROOF-MOUNTED LADDER	⊕	STRUCTURAL SKYLIGHT
⊕	CAGED LADDER	⊕	CHIMNEY
⊕	WALL-MOUNTED LADDER	⊕	ROUND GOOSENECK
⊕	WALKPAD	⊕	SQUARE GOOSENECK
⊕	SPLASHBLOCK	⊕	RISE-WALL
⊕	12" WALL THICKNESS INDICATOR	⊕	DIRECTION OF SLOPE
⊕	2" WALL HEIGHT INDICATOR	⊕	RIDGE / VALLEY
⊕	DOOR ACCESS	⊕	GUY WIRE ANCHOR
⊕	LIGHT	⊕	TILE ROOF
⊕	SHINGLE ROOF	⊕	METAL ROOF
⊕	ANTENNA	⊕	COLUMN
⊕	A2 AREA IDENTIFICATION	⊕	SUSPECTED WET AREA
⊕	CORE LOCATION	⊕	PHOTO LOCATION
⊕	LEAK LOCATION	⊕	PROBE LOCATION
⊕	INFRARED I.D.	⊕	TIE-BACK
⊕	TEST LOCATION		

NEW PARTIAL ROOF PLAN: AREA "A" (BASE BID)  
 SCALE: 1/16"=1'-0" (11"x17"); 1/8"=1'-0" (22"x34")

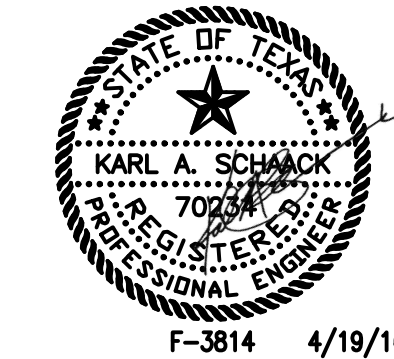

F-3814 4/19/16

**PRICE CONSULTING, INC.**  
 PRICE CONSULTING, INC.  
 211 HIGHLAND CROSS, SUITE 220  
 HOUSTON, TEXAS 77073  
 PHONE: (281)209-1724 FAX: (281)209-2724

PROJECT:  
 UTHSC - SCHOOL OF NURSING  
 6901 BERTNER AVE  
 HOUSTON, TX

OWNER/CLIENT:  
 UT HEALTH SCIENCE CENTER AT HOUSTON  
 7000 FANNIN, UCT M125  
 HOUSTON, TEXAS 77030

REVISIONS		
NO.	DATE	BY

ROOF PLAN  
 PCI PROJECT NO.: 11204.15  
 PCI FILE NAME: R2.00-R2.05  
 SCALE: AS NOTED

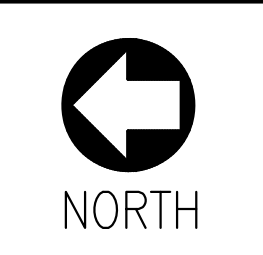

DWN.BY: DATE:  
 ESG 04/19/16  
 SHEET:  
 R2.03

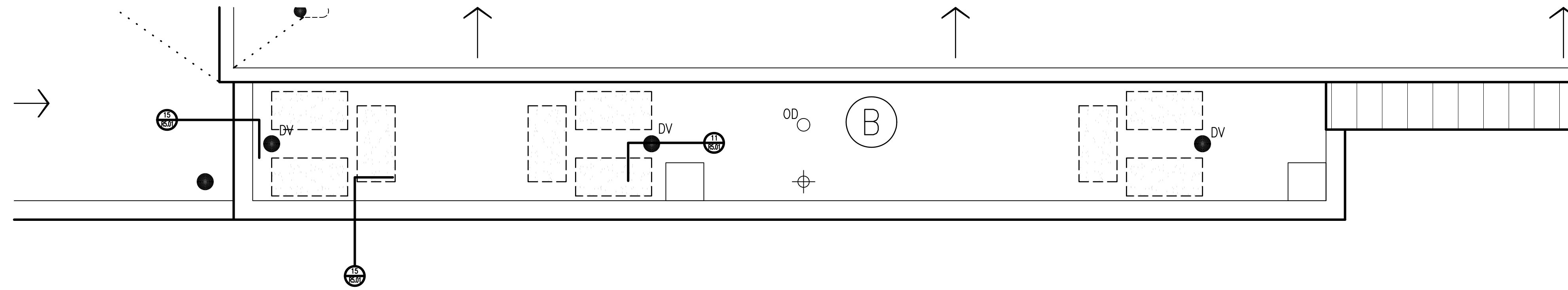

NEW PARTIAL ROOF PLAN: AREA "B" (ALT. BID NO. 1)  
SCALE: 1/8"=1'-0"(11'x17"); 1/4"=1'-0"(22'x34")

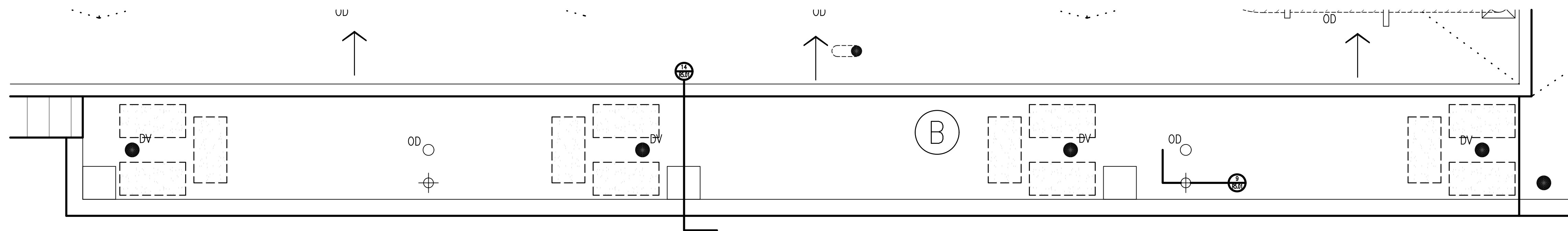

NEW PARTIAL ROOF PLAN: AREA "B" (ALT. BID NO. 1)  
SCALE: 1/8"=1'-0"(11'x17"); 1/4"=1'-0"(22'x34")

LEGEND			
○ <sup>OD</sup>	OVERFLOW DRAIN	△	WALL DRAIN
⊕	ROOF DRAIN	⊕	SUMPED DRAIN
⊗	PLUMBING VENT	⊙	HEAT EXHAUST
⊠	POWER VENT	⊠	CURBED HEAT EXHAUST
⊠	CURBED VENT STACK	⊕	GRAVITY VENT
⊗	TURBINE VENT	⊙	GRAVITY VENT
⊗	CURBED TURBINE VENT	⊙	MOISTURE RELIEF VENT
●	ROUND PENETRATION	⊙	GOOSENECK PENETRATION
⊠	ABANDONED PENETRATION	⊠	PIPE BOX
⊕	PIPING ON HANGERS	---	EXPANSION JOINT
⊕	PIPING ON WOOD BLOCKING	---	ROOF-TO-WALL EXPANSION JOINT
⊕	PIPING ON SUPPORTS	---	METAL EDGE
---	PARAPET	---	DOWNSPOUT AND GUTTER
-CD-	CONDENSATION DRAIN LINE	-MS-	MECHANICAL SCREEN
-E-	ELECTRICAL CONDUIT	-W-	CHILL / HOT WATER
-G-	GAS LINE	⊙	AIR TERMINAL
■	PITCH PAN	⊙	THROUGH-ROOF CONNECTION
⊠	DUCT PENETRATION	⊠	CURBED DUCT PENETRATION
⊠	EQUIPMENT CURB	⊕	DUCT WITH DUCT SUPPORT
⊠	VENT / INTAKE	⊕	THROUGH-WALL SCUPPER
⊠	GRAVITY VENT	⊕	THROUGH-EDGE SCUPPER
⊕	SCUPPER WITH COLLECTOR HEAD	⊕	EQUIPMENT ON SLEEPERS
⊕	EQUIPMENT ON SUPPORTS	⊕	EQUIPMENT ON CURBS
⊕	EQUIPMENT ON PITCH PANS	⊕	ROOF HATCH
⊕	SMOKE HATCH	⊕	SKYLIGHT
⊕	SATELLITE DISH	⊕	STRUCTURAL SKYLIGHT
⊕	ROOF-MOUNTED LADDER	⊕	STRUCTURAL SKYLIGHT
⊕	CAGED LADDER	⊕	CHIMNEY
⊕	WALL-MOUNTED LADDER	⊕	ROUND GOOSENECK
⊕	WALKPAD	⊕	SQUARE GOOSENECK
⊕	SPLASHBLOCK	⊕	RISE-WALL
12"	WALL THICKNESS INDICATOR	⊕	DIRECTION OF SLOPE
2"	WALL HEIGHT INDICATOR	⊕	TRIDGE / VALLEY
△	DOOR ACCESS	⊕	GUY WIRE ANCHOR
⊕	LIGHT	⊕	TILE ROOF
⊕	SHINGLE ROOF	⊕	METAL ROOF
⊕	ANTENNA	⊕	COLUMN
⊕	AREA IDENTIFICATION	⊕	SUSPECTED WET AREA
⊕	CORE LOCATION	⊕	PHOTO LOCATION
⊕	LEAK LOCATION	⊕	PROBE LOCATION
⊕	INFRARED I.D.	⊕	TIE-BACK
⊕	TEST LOCATION	⊕	

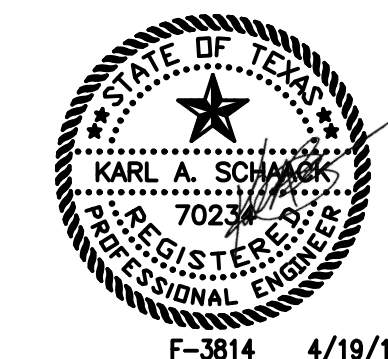

F-3814 4/19/16

**PRICE CONSULTING, INC.**  
PRICE CONSULTING, INC.  
211 HIGHLAND CROSS, SUITE 220  
HOUSTON, TEXAS 77073  
PHONE: (281)209-1724 FAX: (281)209-2724

PROJECT:  
UTHSC - SCHOOL OF NURSING  
6901 BERTNER AVE  
HOUSTON, TX

OWNER/CLIENT:  
UT HEALTH SCIENCE CENTER AT HOUSTON  
7000 FANNIN, UCT M125  
HOUSTON, TEXAS 77030

REVISIONS		
NO.	DATE	BY

ROOF PLAN  
PCI PROJECT NO.: 11204.15  
PCI FILE NAME: R2.00-R2.05  
SCALE: AS NOTED

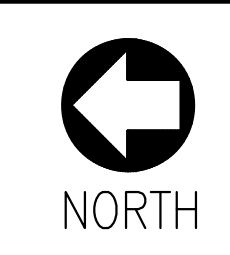

DWN.BY: DATE:  
ESG 04/19/16  
SHEET:  
R2.04

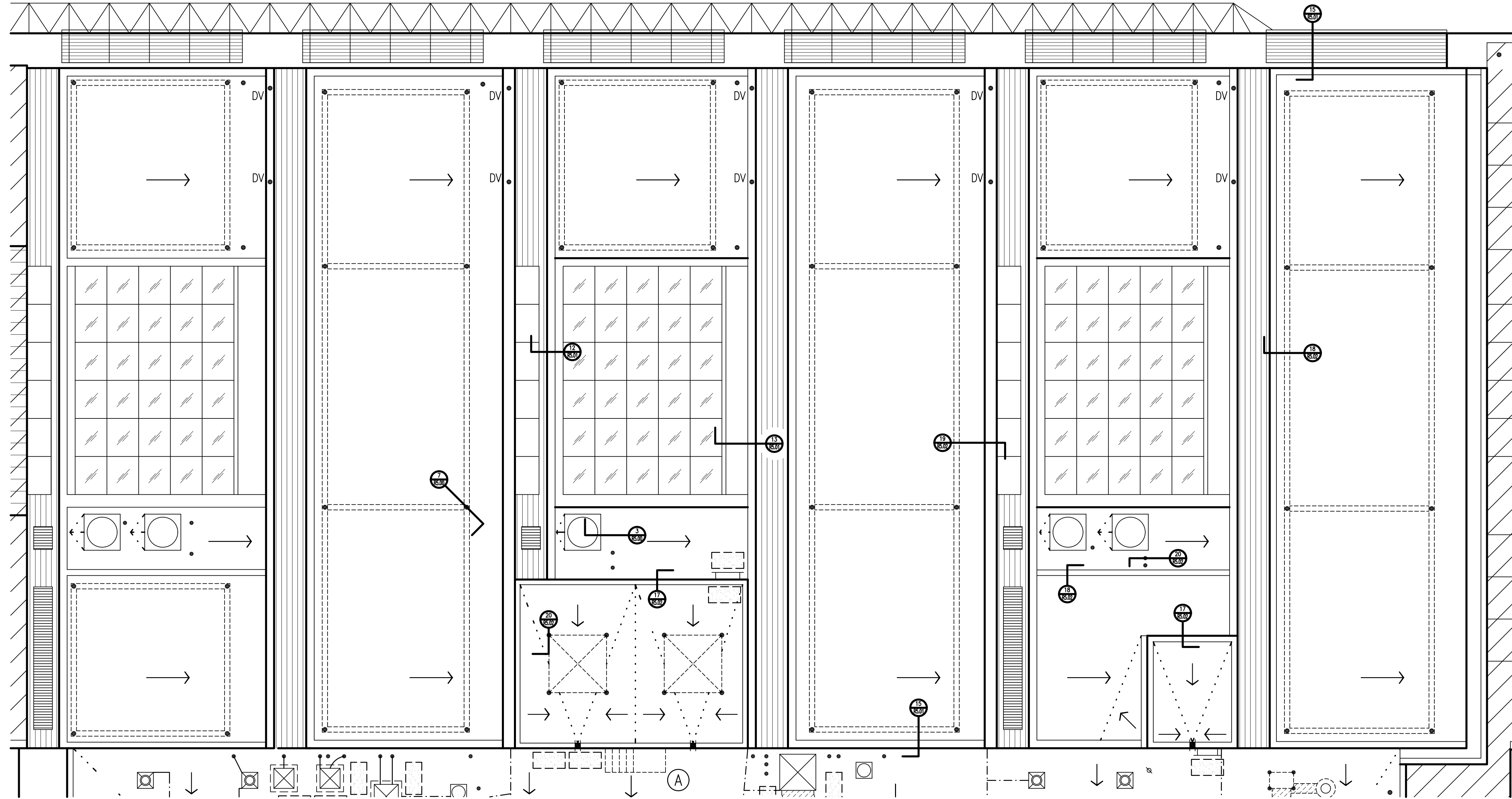

LEGEND			
○ <sup>OD</sup>	OVERFLOW DRAIN	△	WALL DRAIN
⊕	ROOF DRAIN	⊕	SUMPED DRAIN
⊗	PLUMBING VENT	⊙	HEAT EXHAUST
⊙	POWER VENT	⊗	CURBED HEAT EXHAUST
⊗	CURBED VENT STACK	⊕	GRAVITY VENT
⊗	TURBINE VENT	⊙	GRAVITY VENT
⊗	CURBED TURBINE VENT	⊙	MOISTURE RELIEF VENT
●	ROUND PENETRATION	⊙	GOOSENECK PENETRATION
⊕	ABANDONED PENETRATION	⊕	PIPE BOX
⊕	PIPING ON HANGERS	—	EXPANSION JOINT
⊕	PIPING ON WOOD BLOCKING	—	ROOF-TO-WALL EXPANSION JOINT
⊕	PIPING ON SUPPORTS	—	METAL EDGE
—	PARAPET	—	DOWNSPOUT AND GUTTER
—	CONDENSATION DRAIN LINE	—	MS - MECHANICAL SCREEN
—	ELECTRICAL CONDUIT	—	W - CHILL / HOT WATER
—	GAS LINE	—	AT - AIR TERMINAL
■	PITCH PAN	—	LP - THROUGH-ROOF CONNECTION
⊕	DUCT PENETRATION	⊕	CURBED DUCT PENETRATION
⊕	EQUIPMENT CURB	⊕	DUCT WITH DUCT SUPPORT
⊕	VENT / INTAKE	⊕	THROUGH-WALL SCUPPER
⊕	GRAVITY VENT	⊕	THROUGH-EDGE SCUPPER
⊕	SCUPPER WITH COLLECTOR HEAD	⊕	EQUIPMENT ON SLEEPERS
⊕	EQUIPMENT ON SUPPORTS	⊕	EQUIPMENT ON CURBS
⊕	EQUIPMENT ON PITCH PANS	⊕	ROOF HATCH
⊕	SMOKE HATCH	⊕	SKYLIGHT
⊕	SATELLITE DISH	⊕	STRUCTURAL SKYLIGHT
⊕	ROOF-MOUNTED LADDER	⊕	STRUCTURAL SKYLIGHT
⊕	CAGED LADDER	⊕	CHIMNEY
⊕	WALL-MOUNTED LADDER	⊕	ROUND GOOSENECK
⊕	WALKPAD	⊕	SQUARE GOOSENECK
⊕	SPLASHBLOCK	⊕	RISE-WALL
12"	WALL THICKNESS INDICATOR	⊕	DIRECTION OF SLOPE
2"	WALL HEIGHT INDICATOR	⊕	RIDGE / VALLEY
△	DOOR ACCESS	⊕	GUY WIRE ANCHOR
⊕	LIGHT	⊕	TILE ROOF
⊕	SHINGLE ROOF	⊕	METAL ROOF
⊕	ANTENNA	⊕	COLUMN
A2	AREA IDENTIFICATION	⊕	SUSPECTED WET AREA
⊕	CORE LOCATION	⊕	PHOTO LOCATION
⊕	LEAK LOCATION	⊕	PROBE LOCATION
⊕	INFRARED I.D.	⊕	TIE-BACK
⊕	TEST LOCATION	⊕	

NEW PARTIAL ROOF PLAN (ALT. BID NO. 2)  
 SCALE: 1/16"=1'-0" (11'x17'); 1/8"=1'-0" (22'x34')

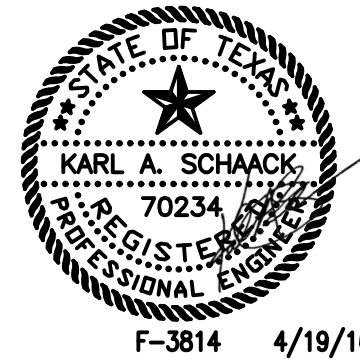

**PRICE CONSULTING, INC.**  
 PRICE CONSULTING, INC.  
 211 HIGHLAND CROSS, SUITE 220  
 HOUSTON, TEXAS 77073  
 PHONE: (281)209-1724 FAX: (281)209-2724

PROJECT:  
 UTHSC - SCHOOL OF NURSING  
 6901 BERTNER AVE  
 HOUSTON, TX

OWNER/CLIENT:  
 UT HEALTH SCIENCE CENTER AT HOUSTON  
 7000 FANNIN, UCT M125  
 HOUSTON, TEXAS 77030

REVISIONS		
NO.	DATE	BY

ROOF PLAN  
 PCI PROJECT NO.: 11204.15  
 PCI FILE NAME: R2.00-R2.05  
 SCALE: AS NOTED

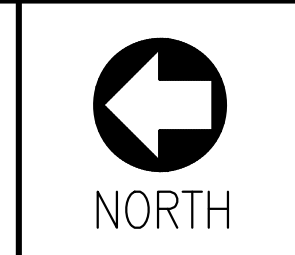

DWN. BY: DATE:  
 ESG 04/19/16  
 SHEET:  
 R2.05



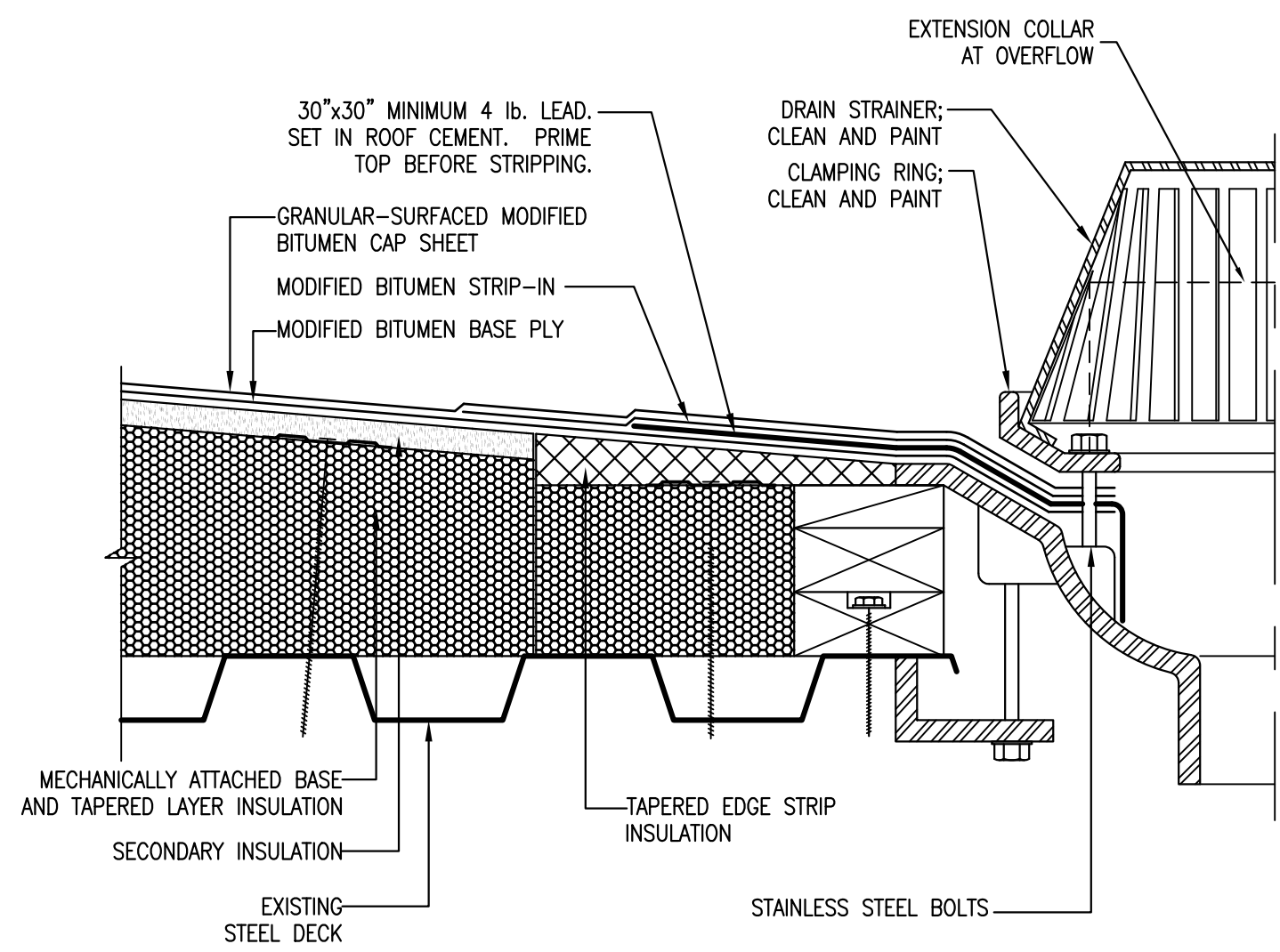

1 ROOF DRAIN (PRIMARY/OVERFLOW)  
R5.00 SCALE: NOT TO SCALE (TYPICAL)

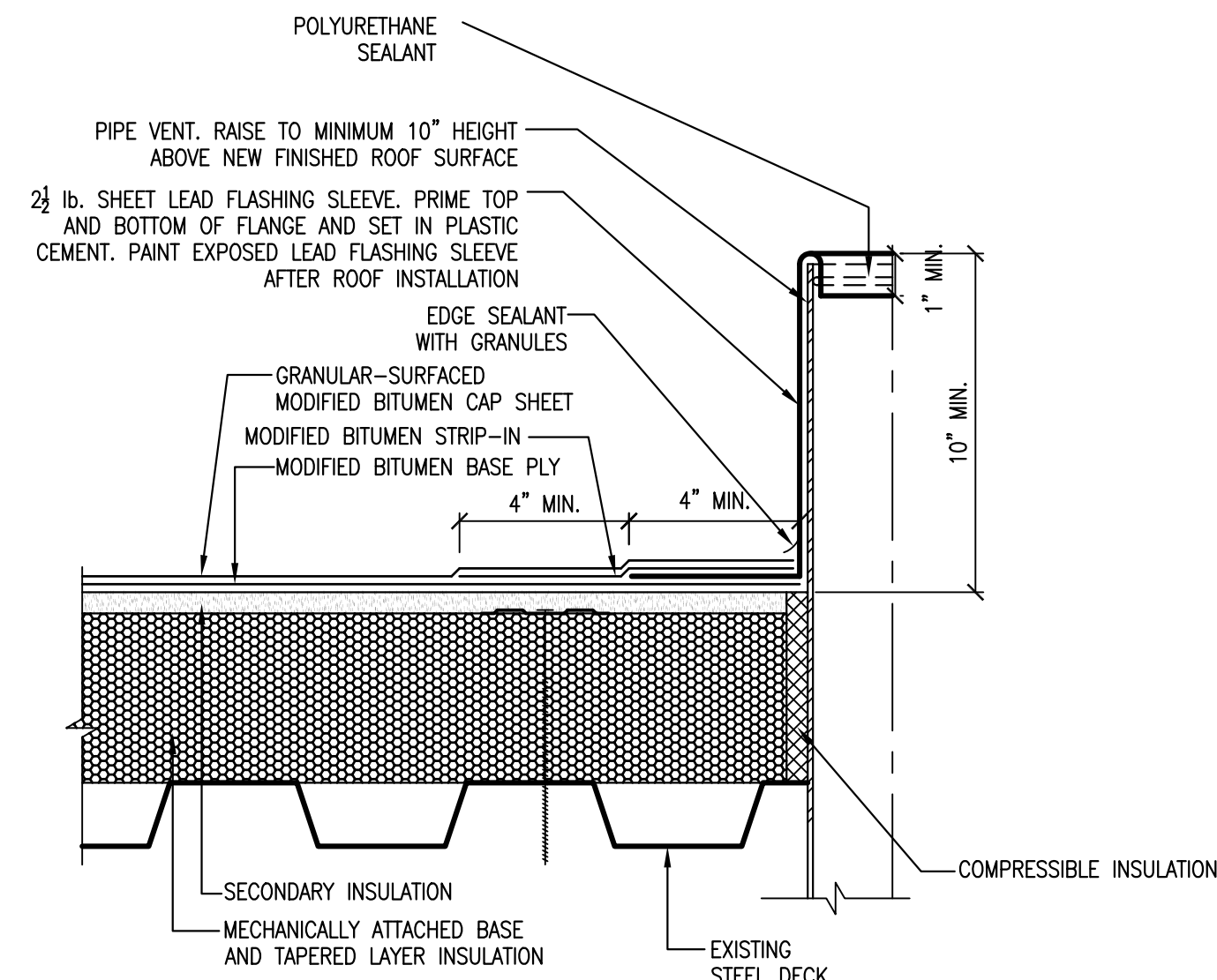

2 PLUMBING VENT  
R5.00 SCALE: NOT TO SCALE (TYPICAL)

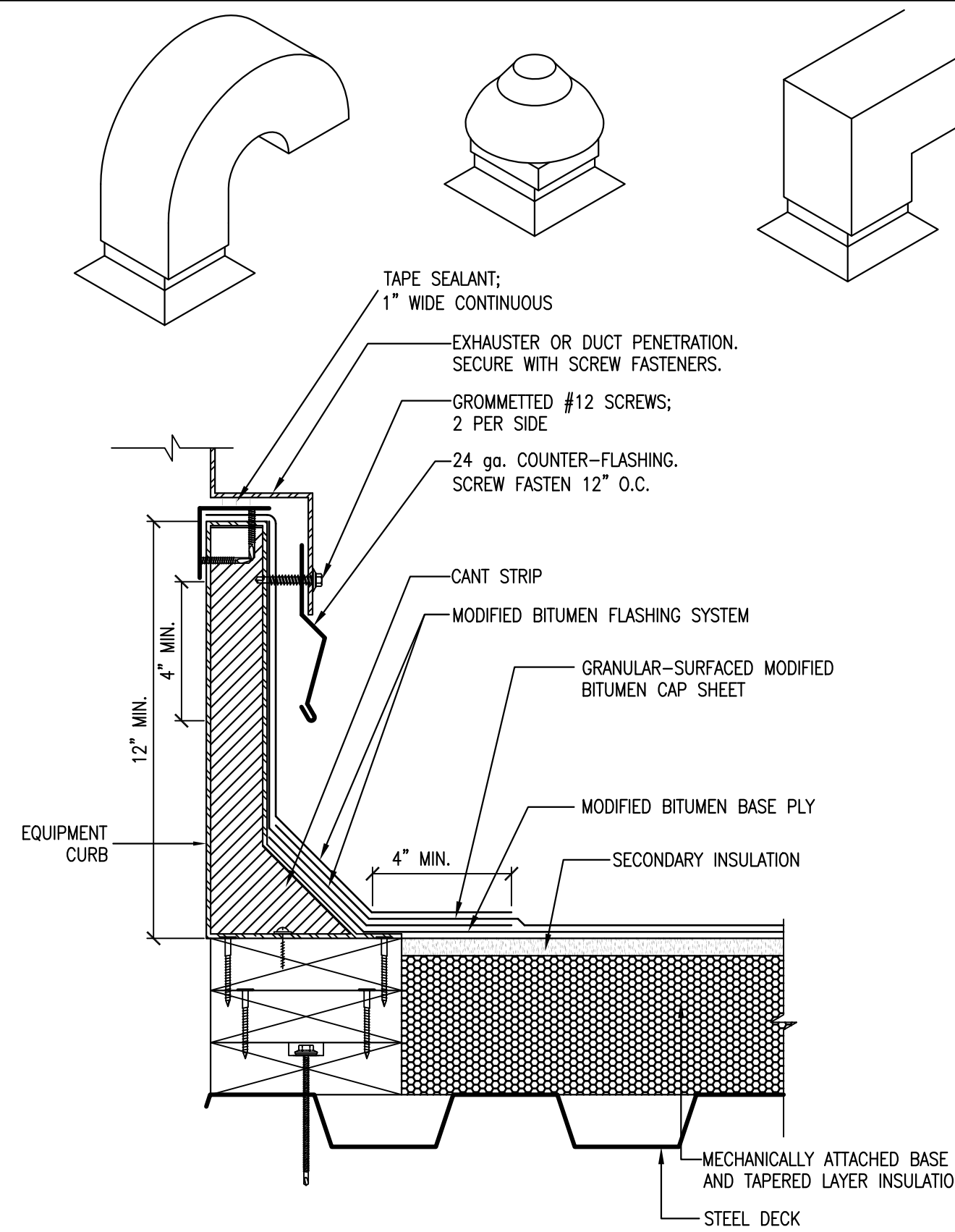

3 CURBED PENETRATION  
R5.00 SCALE: NOT TO SCALE (OPTION #1)

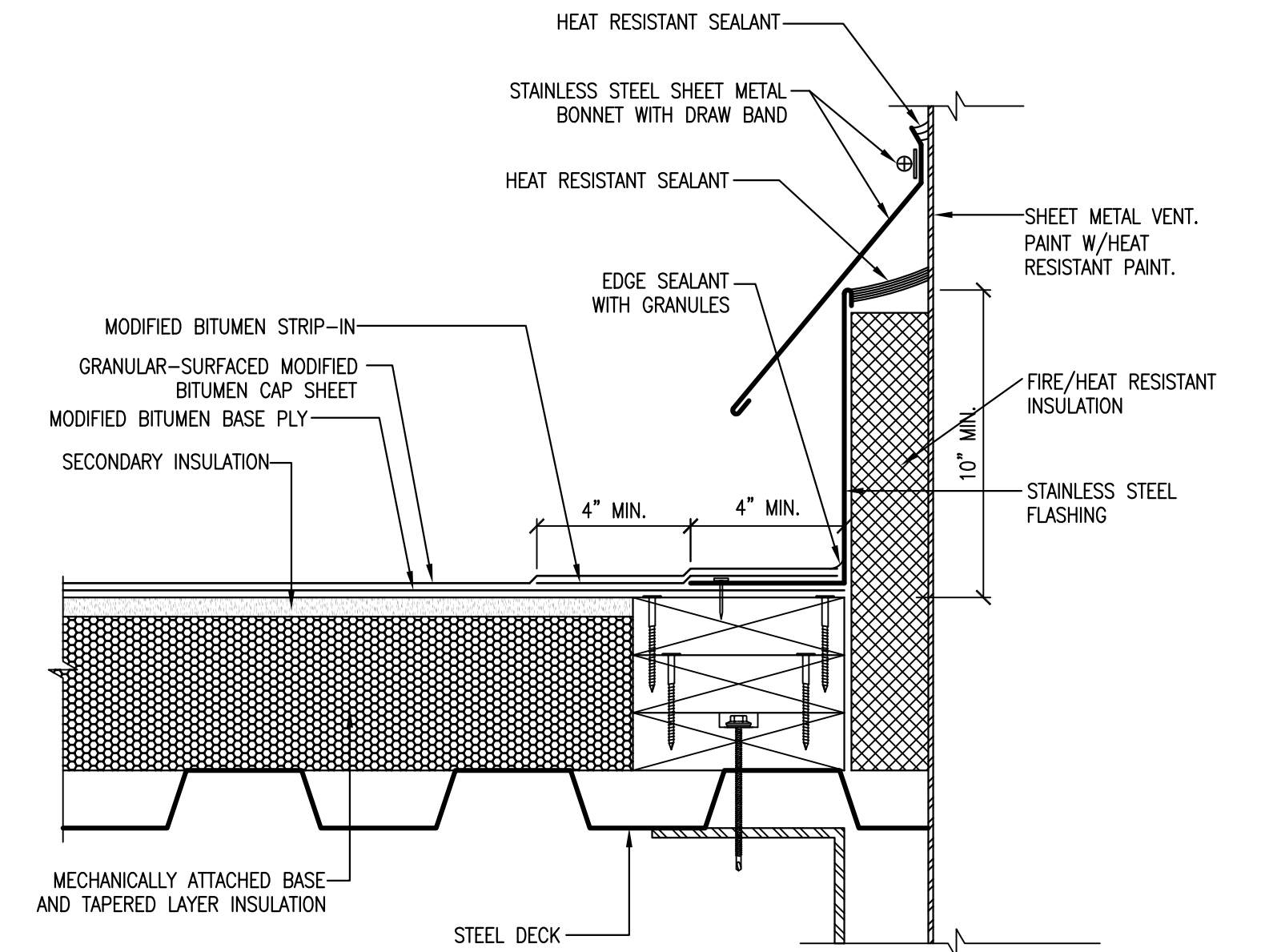

4 HEAT VENT  
R5.00 SCALE: NOT TO SCALE (TYPICAL)

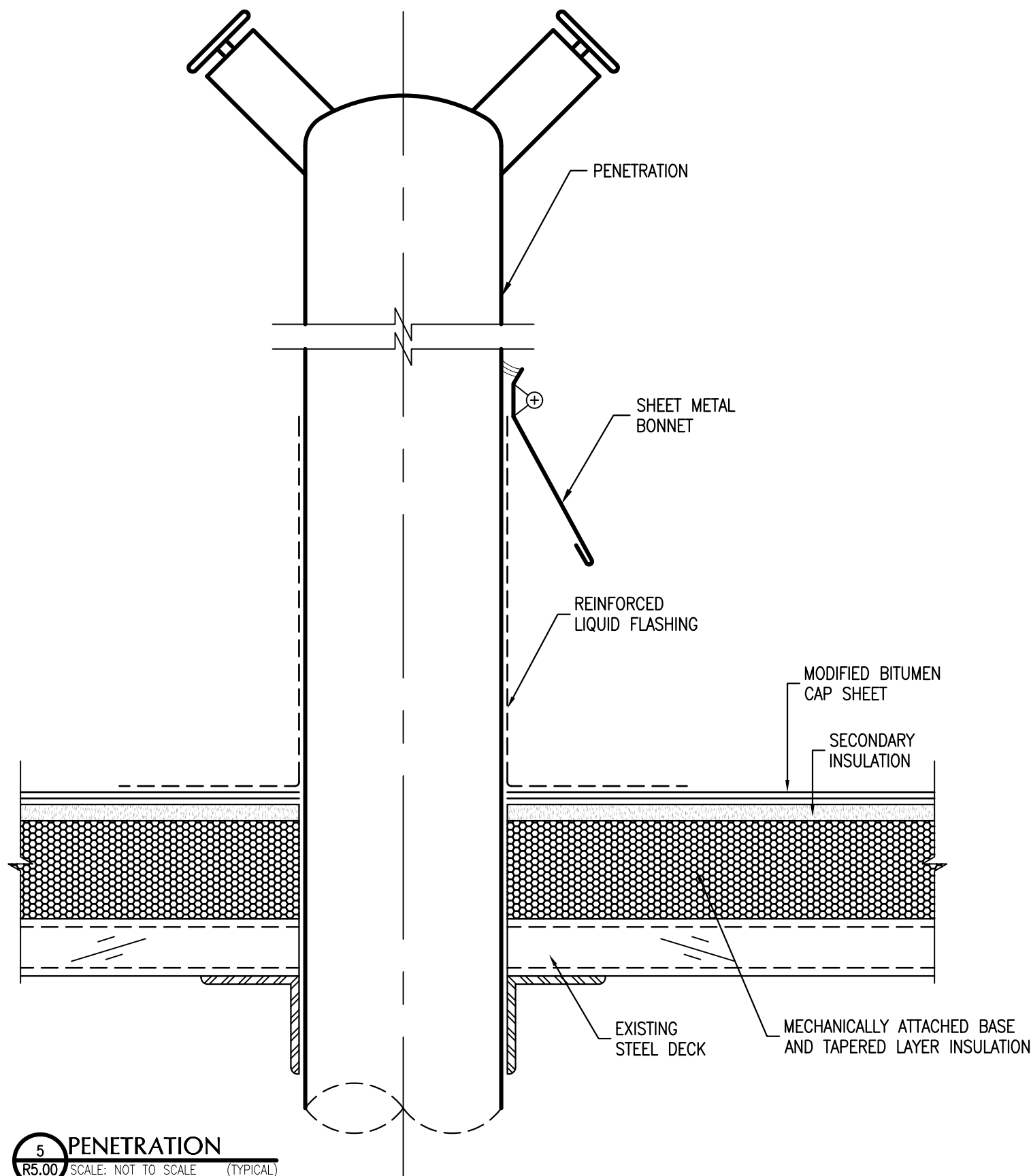

5 PENETRATION  
R5.00 SCALE: NOT TO SCALE (TYPICAL)

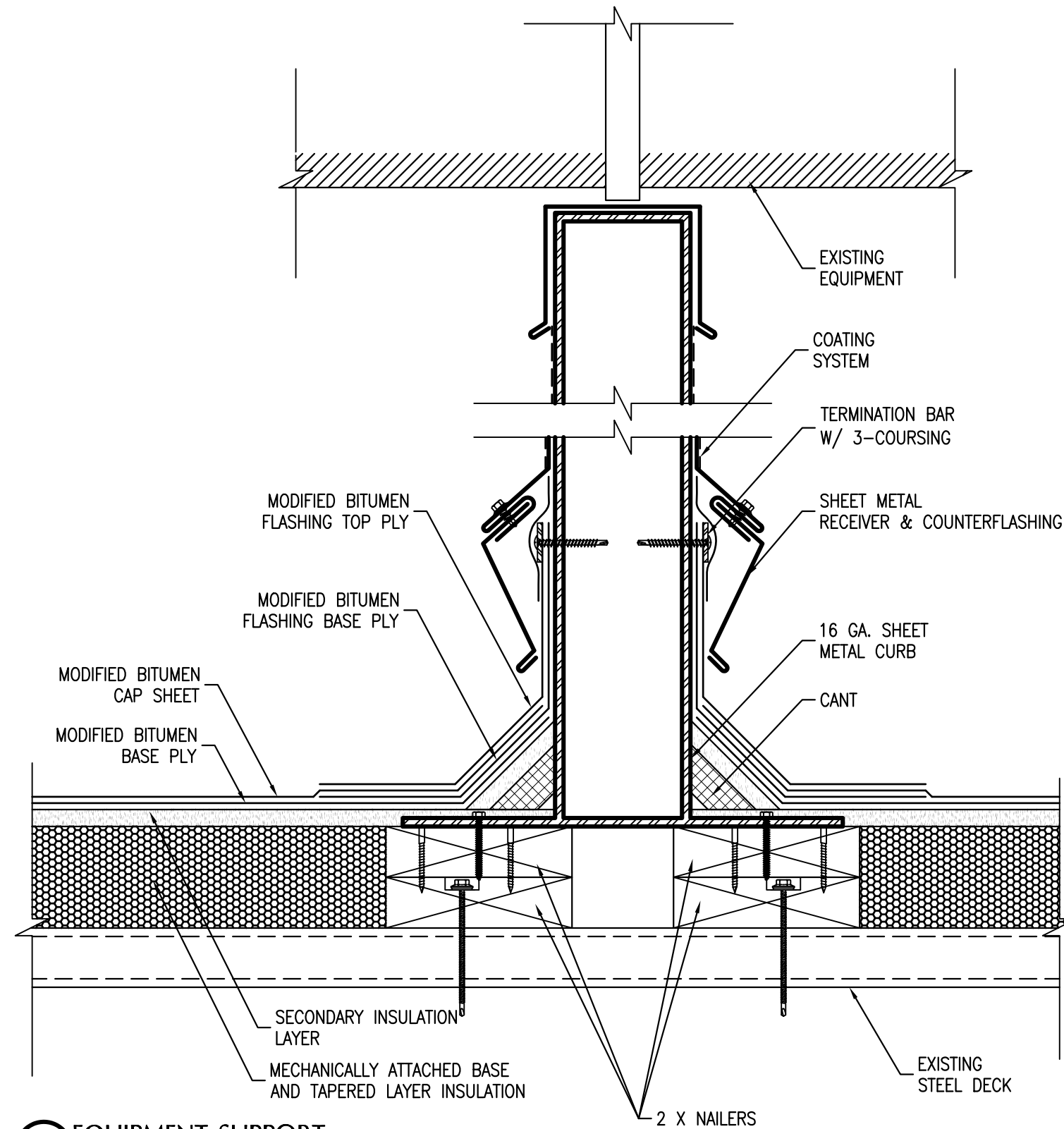

6 EQUIPMENT SUPPORT  
R5.00 SCALE: NOT TO SCALE (TYPICAL)

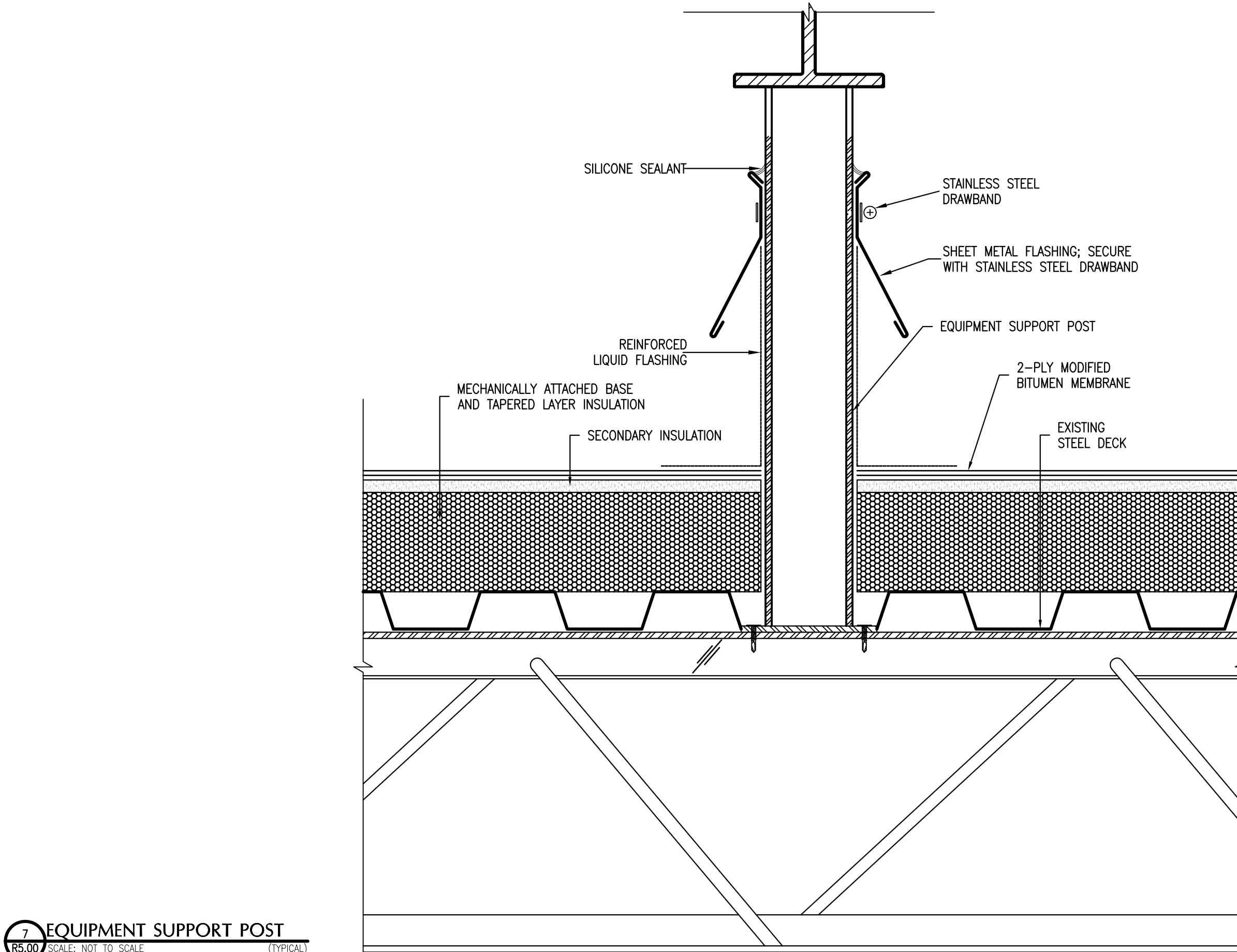

7 EQUIPMENT SUPPORT POST  
R5.00 SCALE: NOT TO SCALE (TYPICAL)

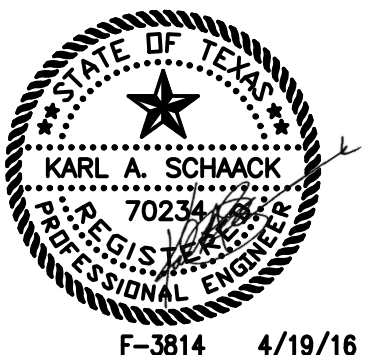

F-3814 4/19/16



PRICE CONSULTING, INC.  
211 HIGHLAND CROSS, SUITE 220  
HOUSTON, TEXAS 77073  
PHONE: (281)209-1724 FAX: (281)209-2724

PROJECT:  
UTHSC - SCHOOL OF NURSING  
6901 BERTNER AVE  
HOUSTON, TX

OWNER/CLIENT:  
UT HEALTH SCIENCE CENTER AT HOUSTON  
7000 FANNIN, UCT M125  
HOUSTON, TEXAS 77030

REVISIONS		
NO.	DATE	BY

DETAILS  
PCI PROJECT NO.: 11204.15  
PCI FILE NAME: R5.00-R5.02  
SCALE: AS NOTED

DWN.BY: DATE:  
ESG 04/19/16  
SHEET:  
R5.00

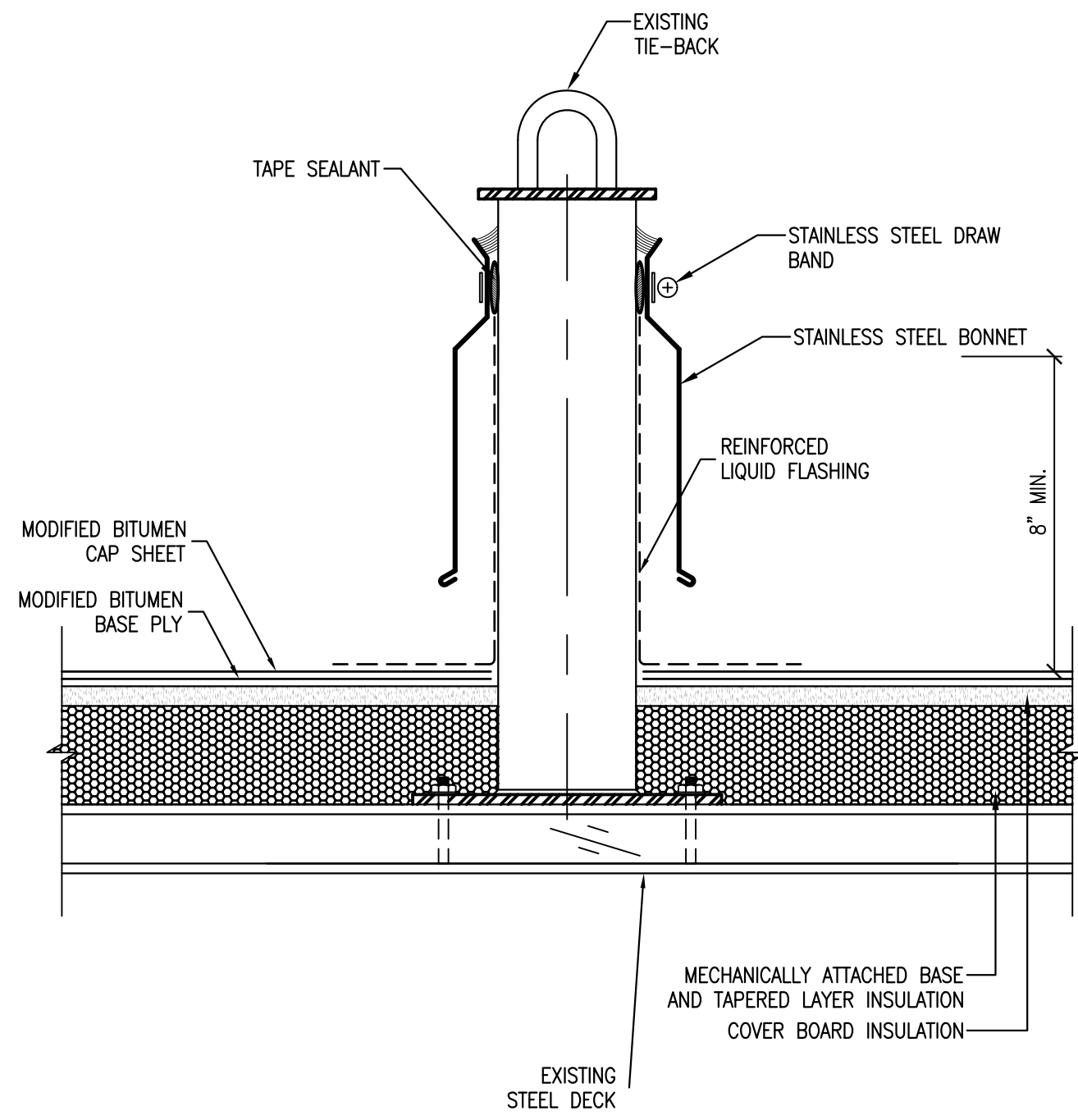

8 TIE-BACK PENETRATION  
R5.01 SCALE: NOT TO SCALE (TYPICAL)

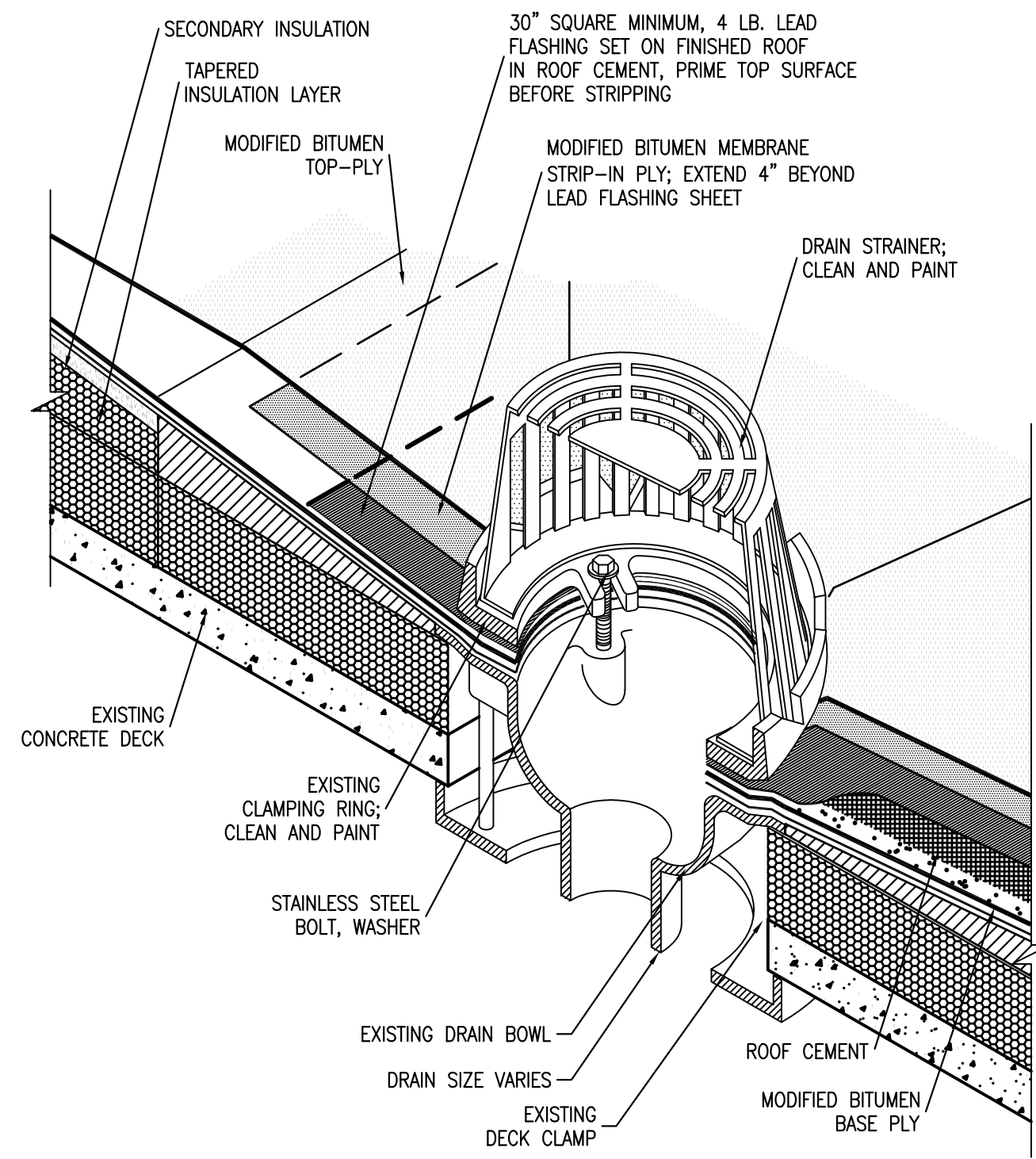

9 ROOF DRAIN  
R5.01 SCALE: NOT TO SCALE (TYPICAL)

END LAP DETAIL:

DURING END LAP APPLICATION, TRIM THE LOWER INSIDE CORNER OF THE UNDERLYING SHEET AT THE END OF THE ROLL AS SHOWN IN DIAGRAM #1, FIGURE A. TRIM THE UPPER OUTSIDE CORNER OF THE OVERLAPPING SHEET AS SHOWN IN DIAGRAM #1, FIGURE B. INSIDE CORNER SHALL BE TRIMMED ON AN ANGLE 5 1/2" LONG FROM END OF ROLL TO OUTSIDE EDGE. WIDTH OF TRIM SHALL BE 3" OR WIDTH OF SELVAGE EDGE OF CAP SHEET. OUTSIDE CORNER SHALL BE TRIMMED IN A ROUNDED MANNER EXTENDING 3" FROM CORNER ALONG BOTH THE SIDE AND END. TRIMMED INSIDE CORNERS SHALL BE COMPLETELY COVERED BY APPLICATION OF SUCCEEDING COURSES. GRANULE SURFACING TO RECEIVE OVERLAPPING PIECE SHALL BE PRIMED OR "DE-GRANULATED" BY PROPER TORCHING METHOD. LOOSE GRANULES SHALL BE BROADCASTED AND EMBEDDED IN BITUMINOUS BLEED OUT ALONG SIDE AND END LAPS.

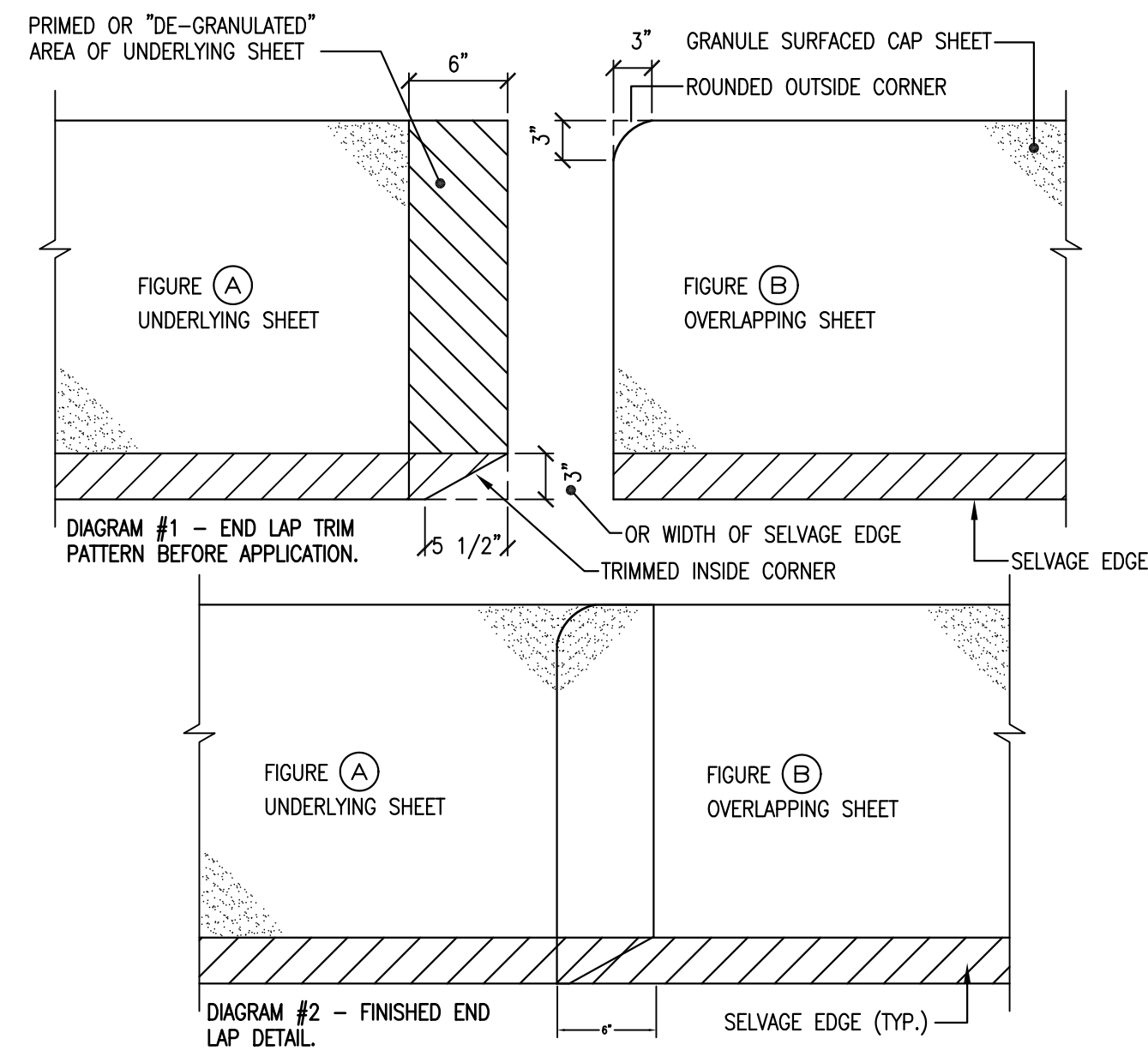

10 GRANULE SURFACED CAP SHEETS: END LAP CONSTRUCTION DETAIL  
R5.01 SCALE: NOT TO SCALE (TYPICAL)

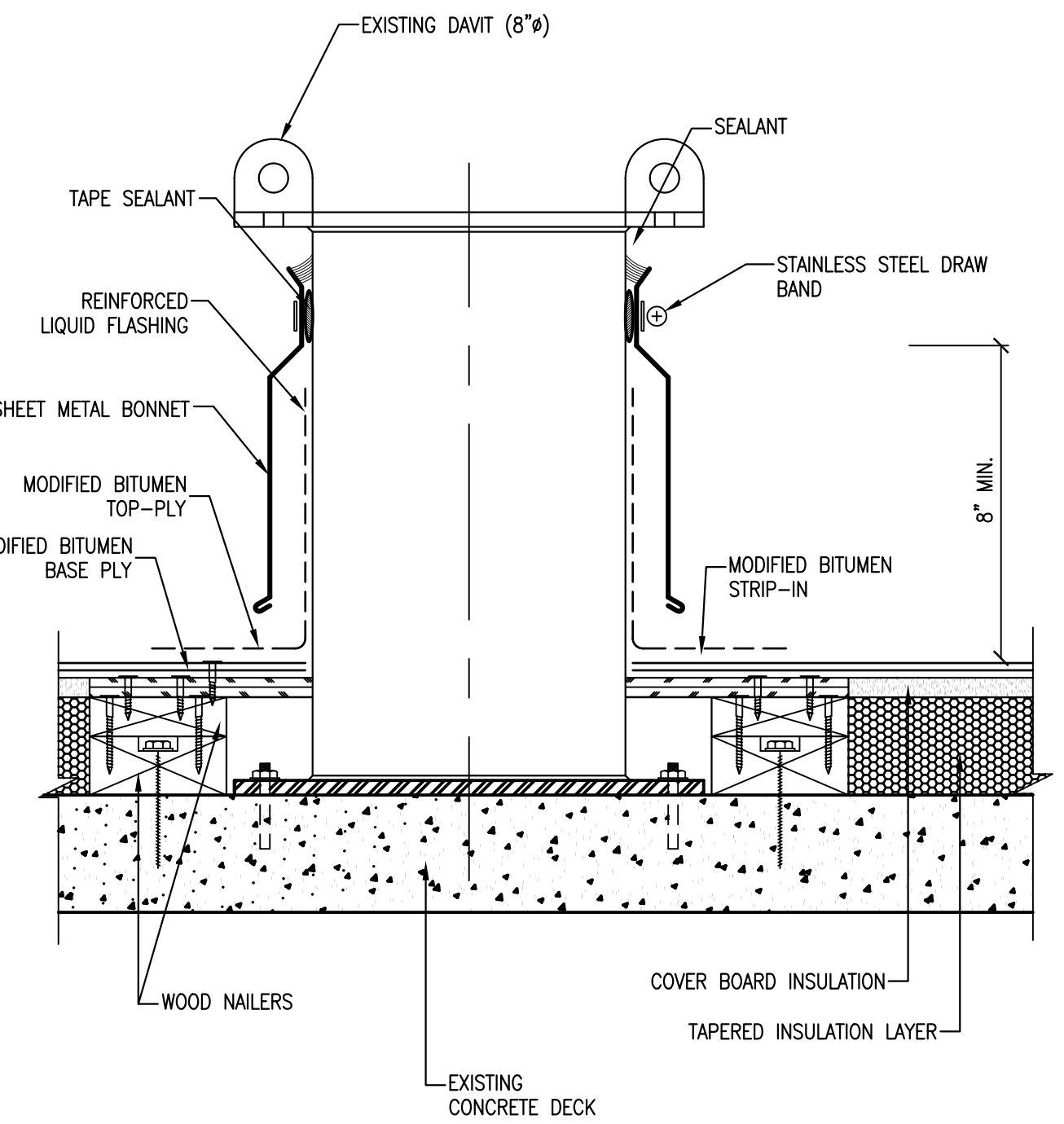

NOTE: 2X WOOD NAILERS ARE DEPICTED FOR INFORMATION PURPOSES ONLY. CONTRACTOR TO INSTALL NECESSARY QUANTITY TO MATCH HEIGHT OF INSULATION.

11 DAVIT  
R5.01 SCALE: NOT TO SCALE (TYPICAL)

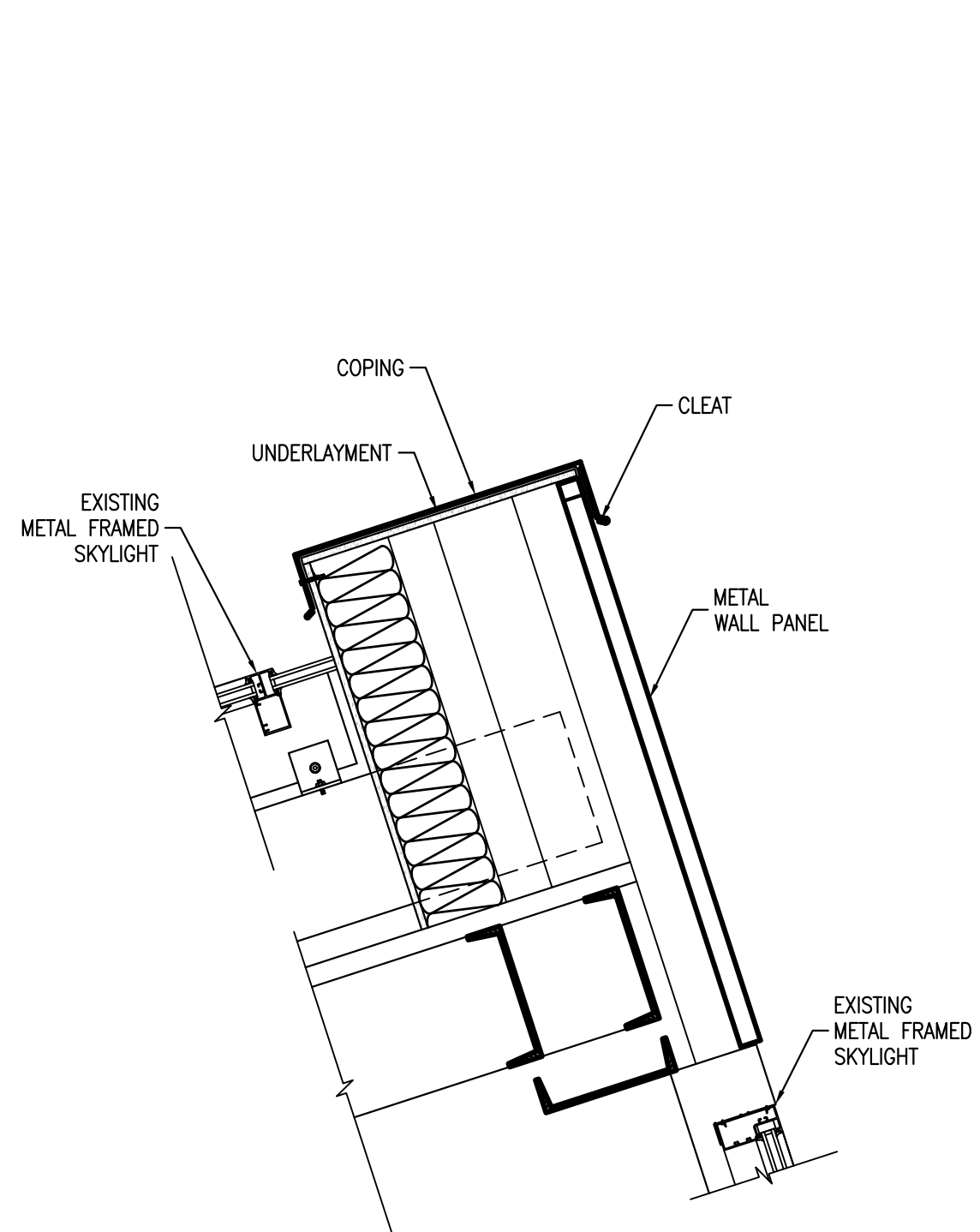

12 ROOF EDGE  
R5.01 SCALE: NOT TO SCALE

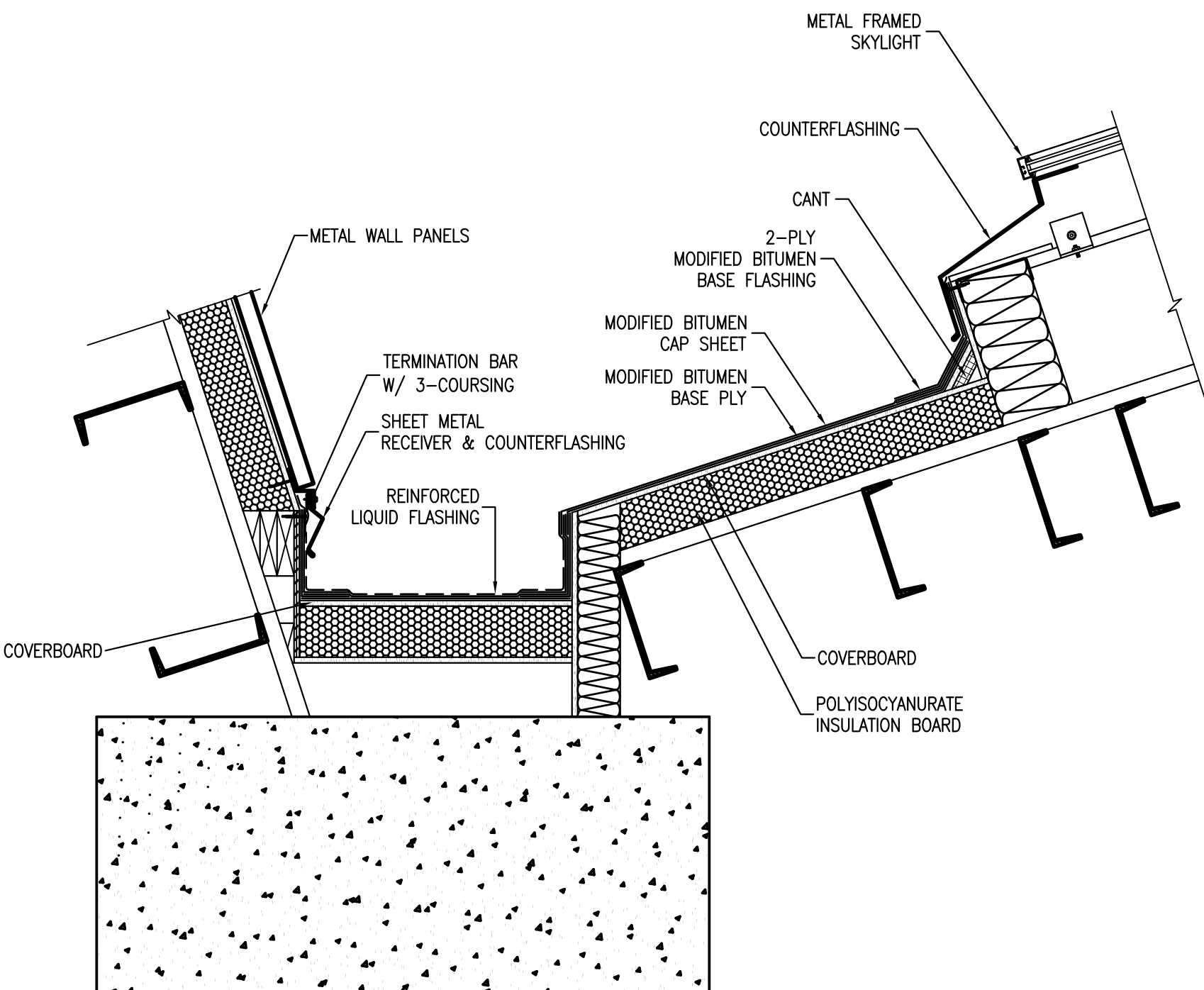

13 INTERNAL GUTTER  
R5.01 SCALE: NOT TO SCALE

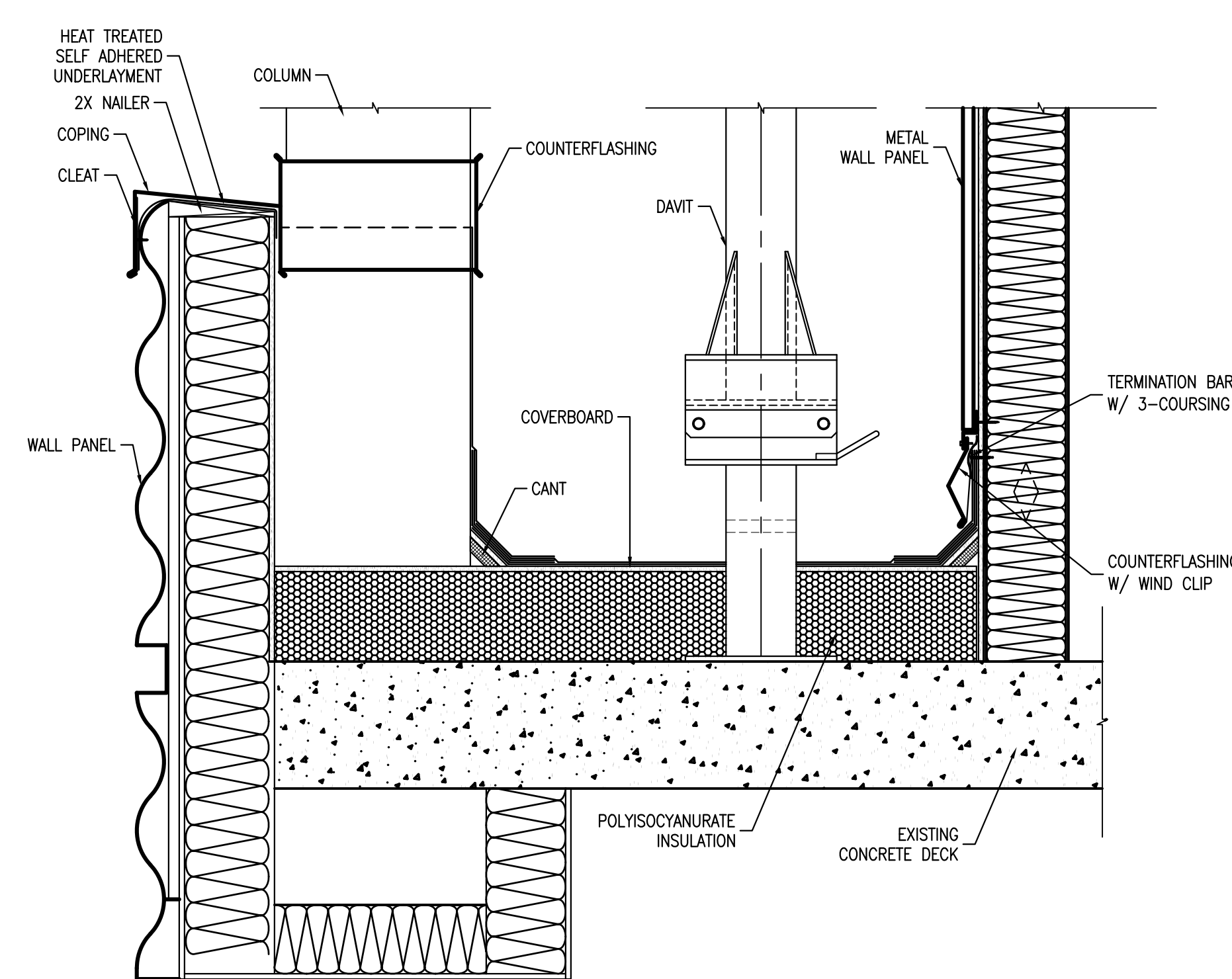

14 RISE WALL  
R5.01 SCALE: NOT TO SCALE

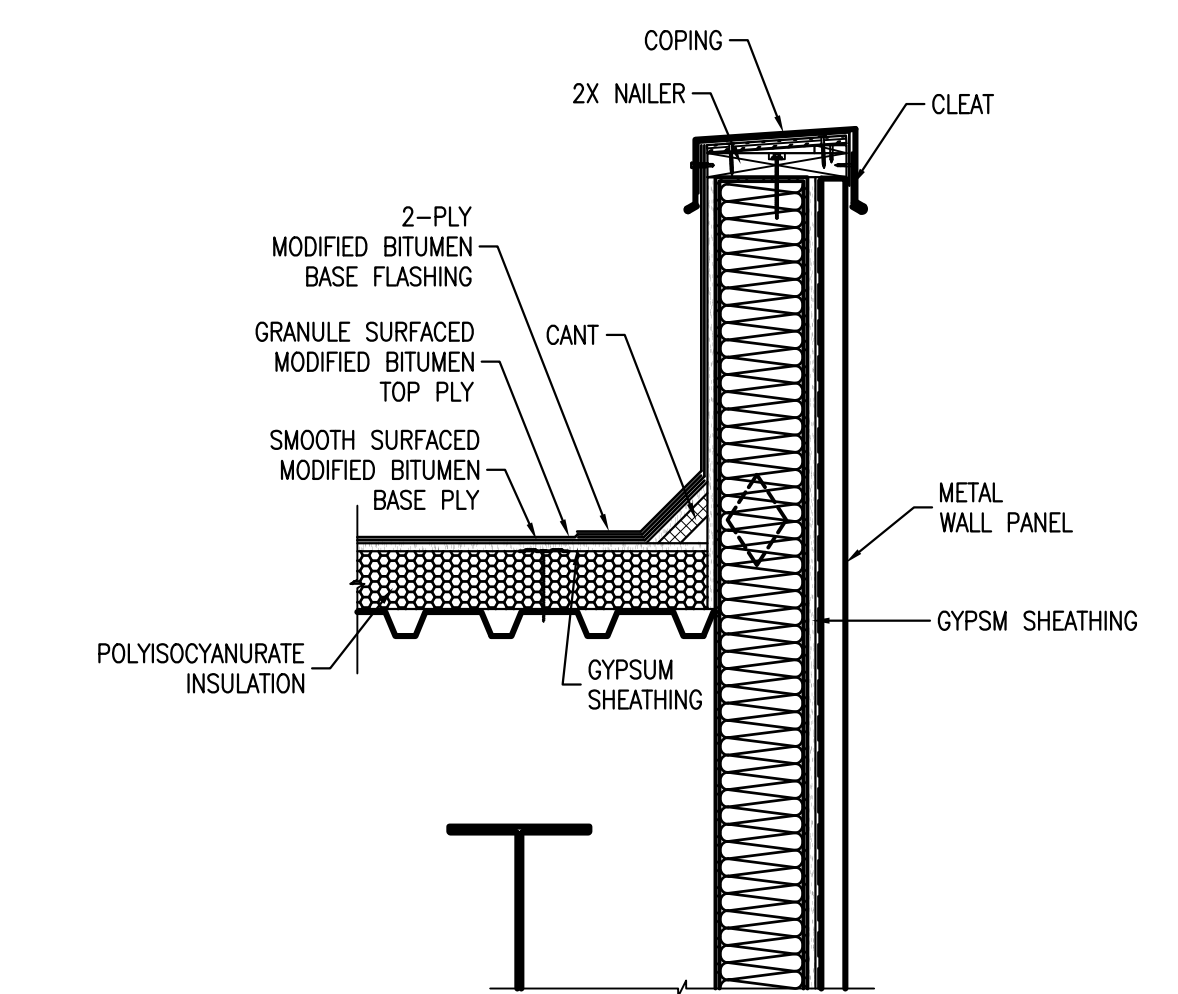

15 PARAPET WALL  
R5.01 SCALE: NOT TO SCALE

**PRICE CONSULTING, INC.**  
PRICE CONSULTING, INC.  
211 HIGHLAND CROSS, SUITE 220  
HOUSTON, TEXAS 77073  
PHONE: (281)209-1724 FAX: (281)209-2724

PROJECT:  
UTHSC - SCHOOL OF NURSING  
6901 BERTNER AVE  
HOUSTON, TX

OWNER/CLIENT:  
UT HEALTH SCIENCE CENTER AT HOUSTON  
7000 FANNIN, UCT M125  
HOUSTON, TEXAS 77030

REVISIONS		
NO.	DATE	BY

DETAILS  
PCI PROJECT NO.: 11204.15  
PCI FILE NAME: R5.00-R5.02  
SCALE: AS NOTED

DWN.BY: DATE:  
ESG 04/19/16  
SHEET:  
R5.01

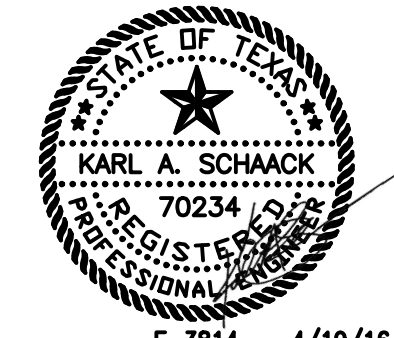

F-3814 4/19/16

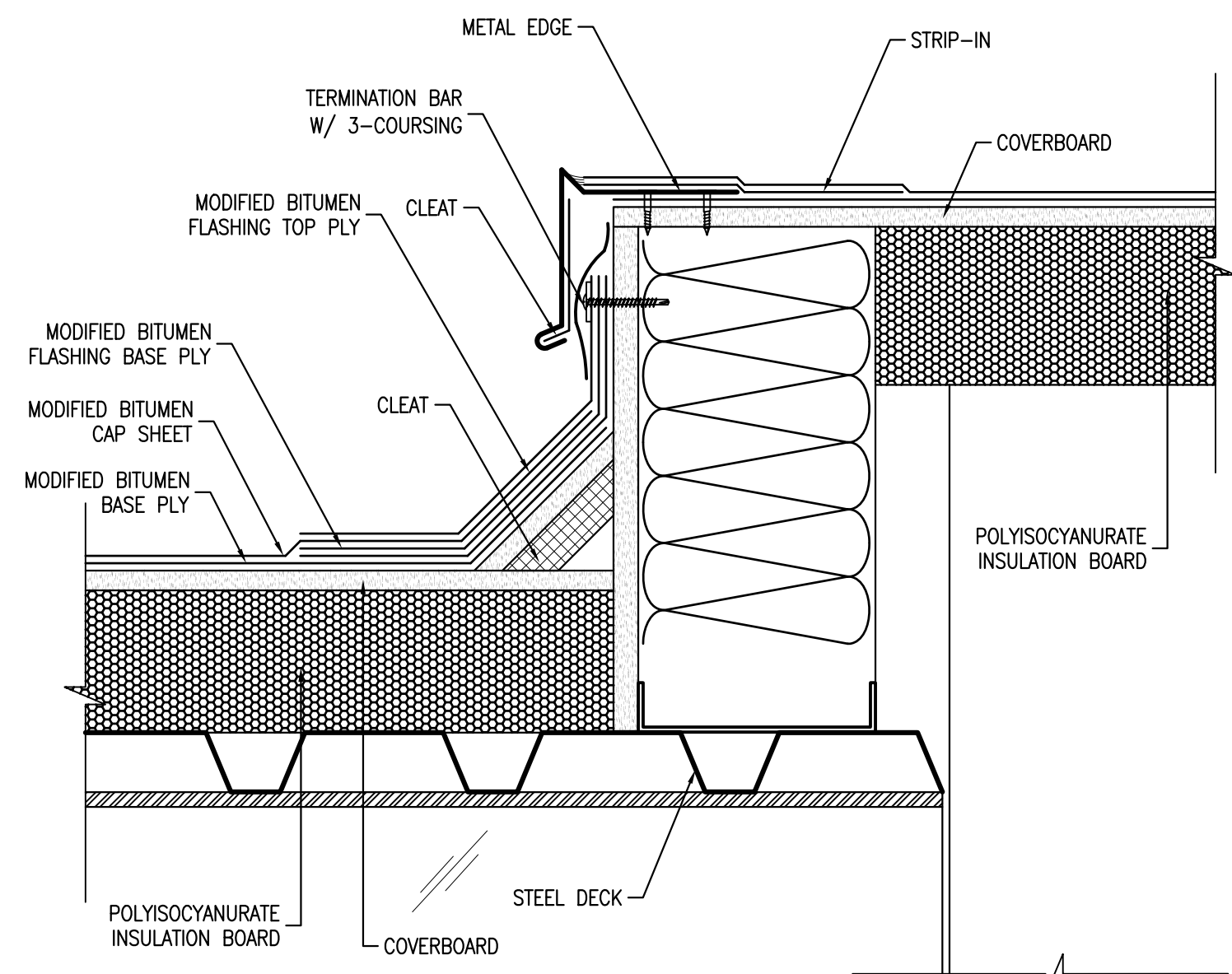

16 ROOF TRANSITION  
R5.02 SCALE: NOT TO SCALE

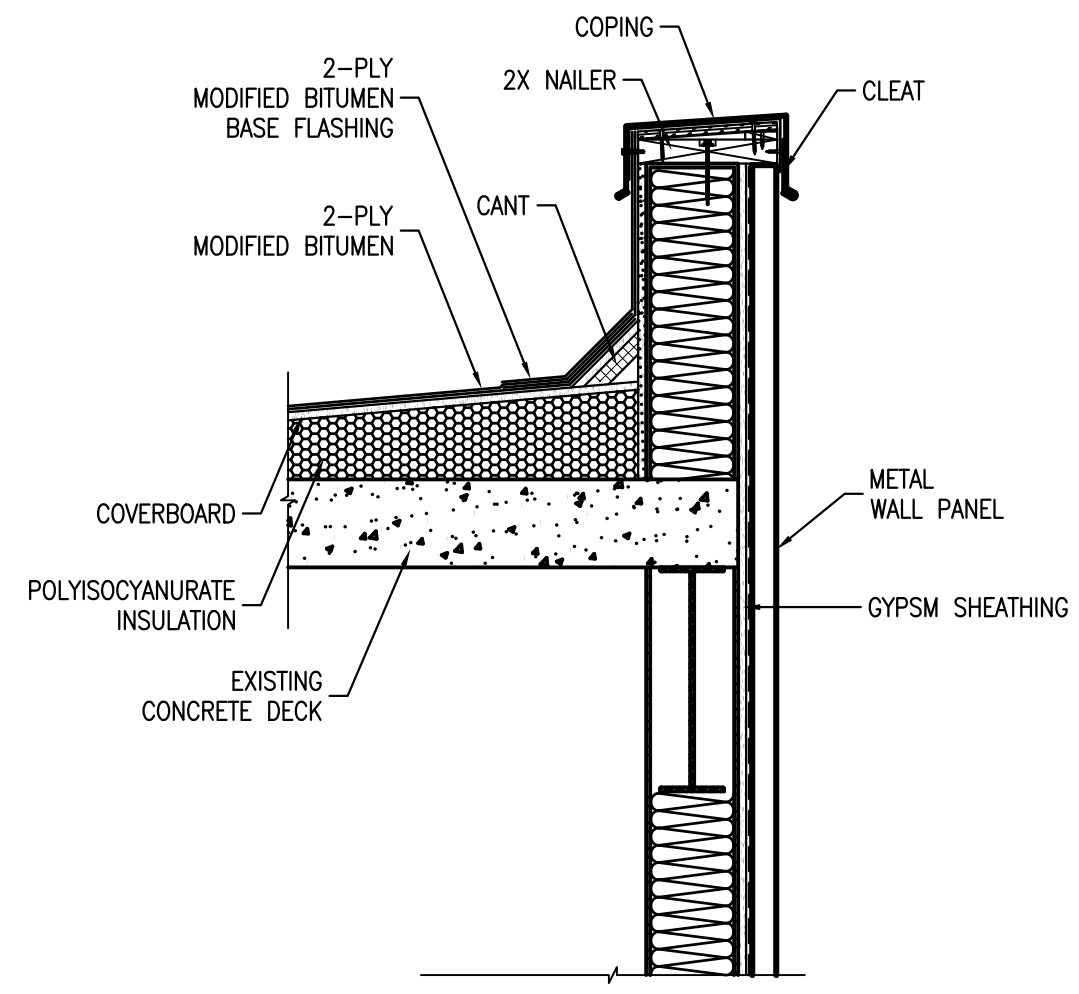

17 PARAPET  
R5.02 SCALE: NOT TO SCALE

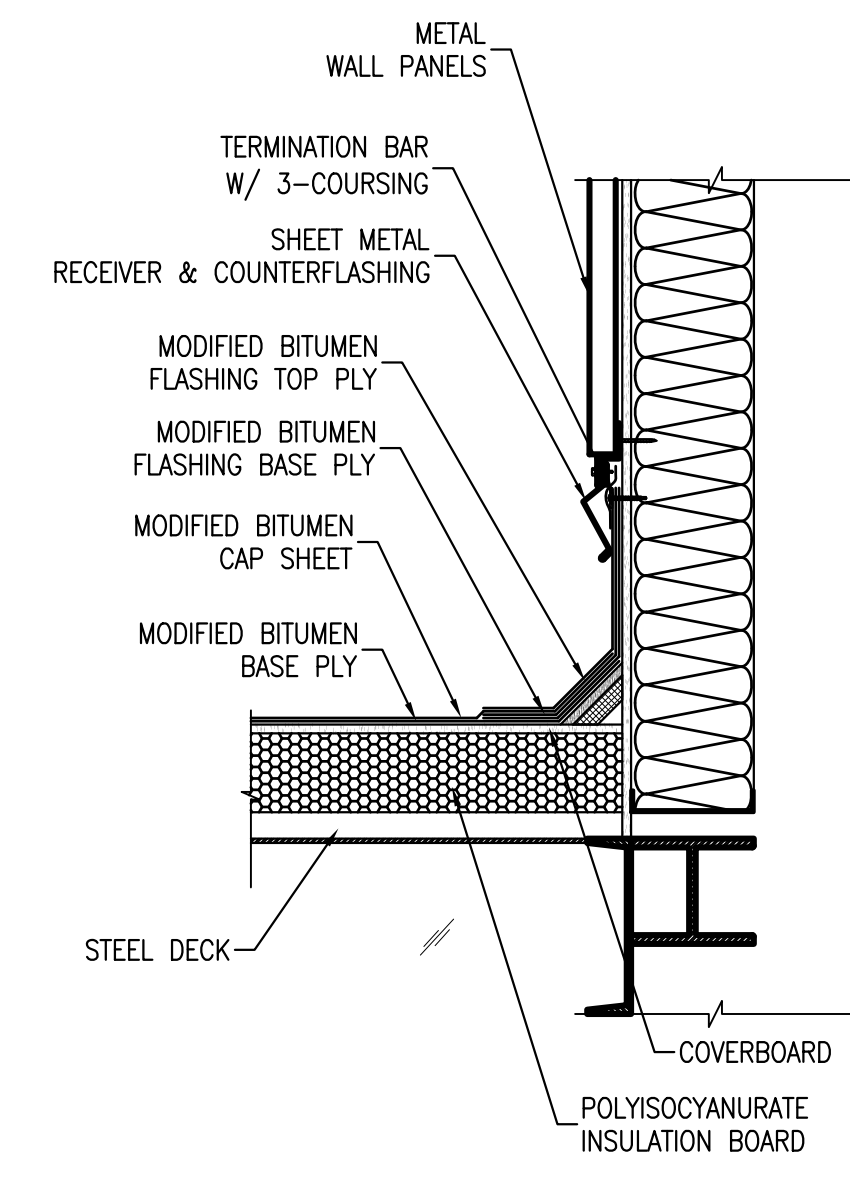

18 RISE WALL  
R5.02 SCALE: NOT TO SCALE

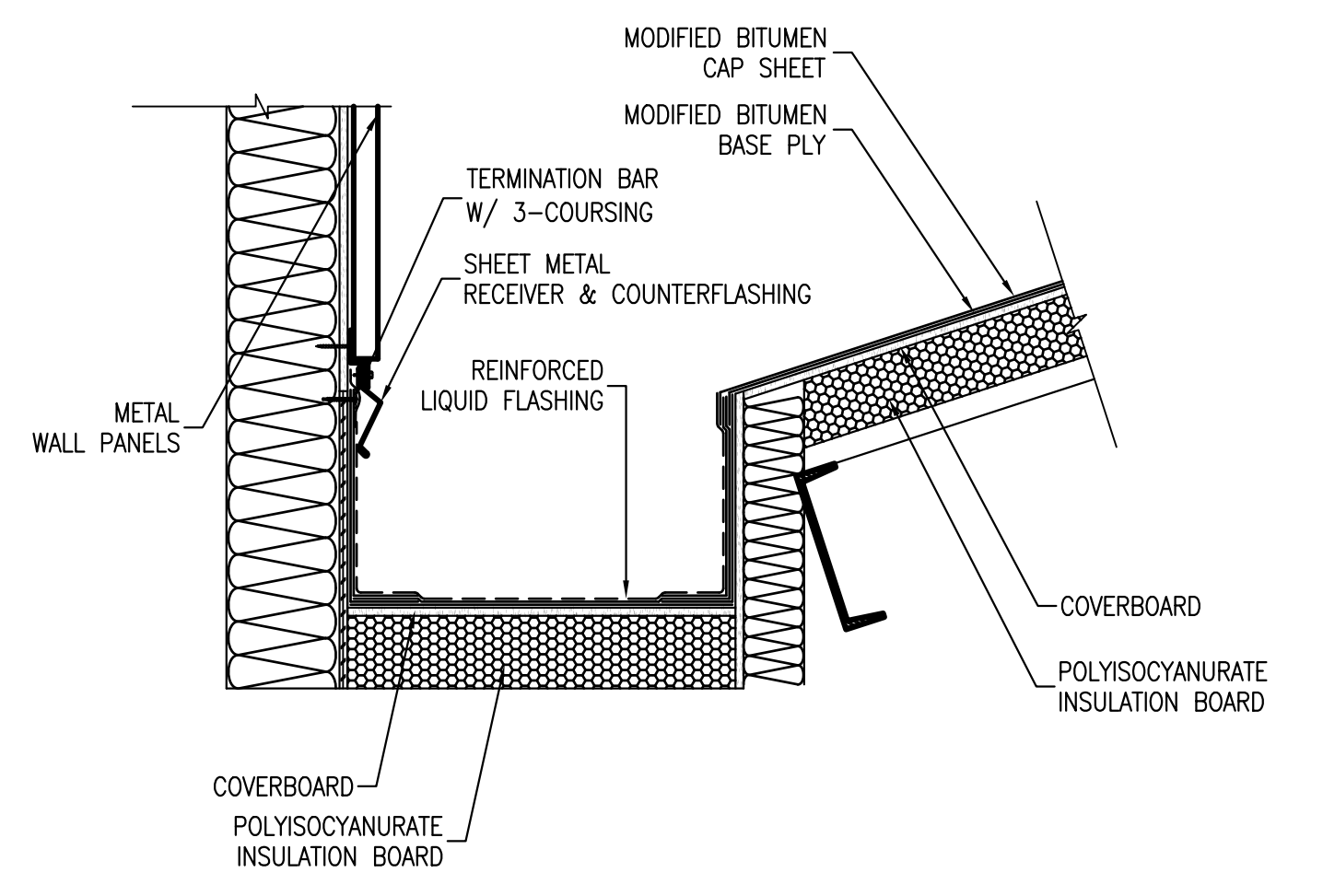

19 INTERNAL GUTTER  
R5.02 SCALE: NOT TO SCALE

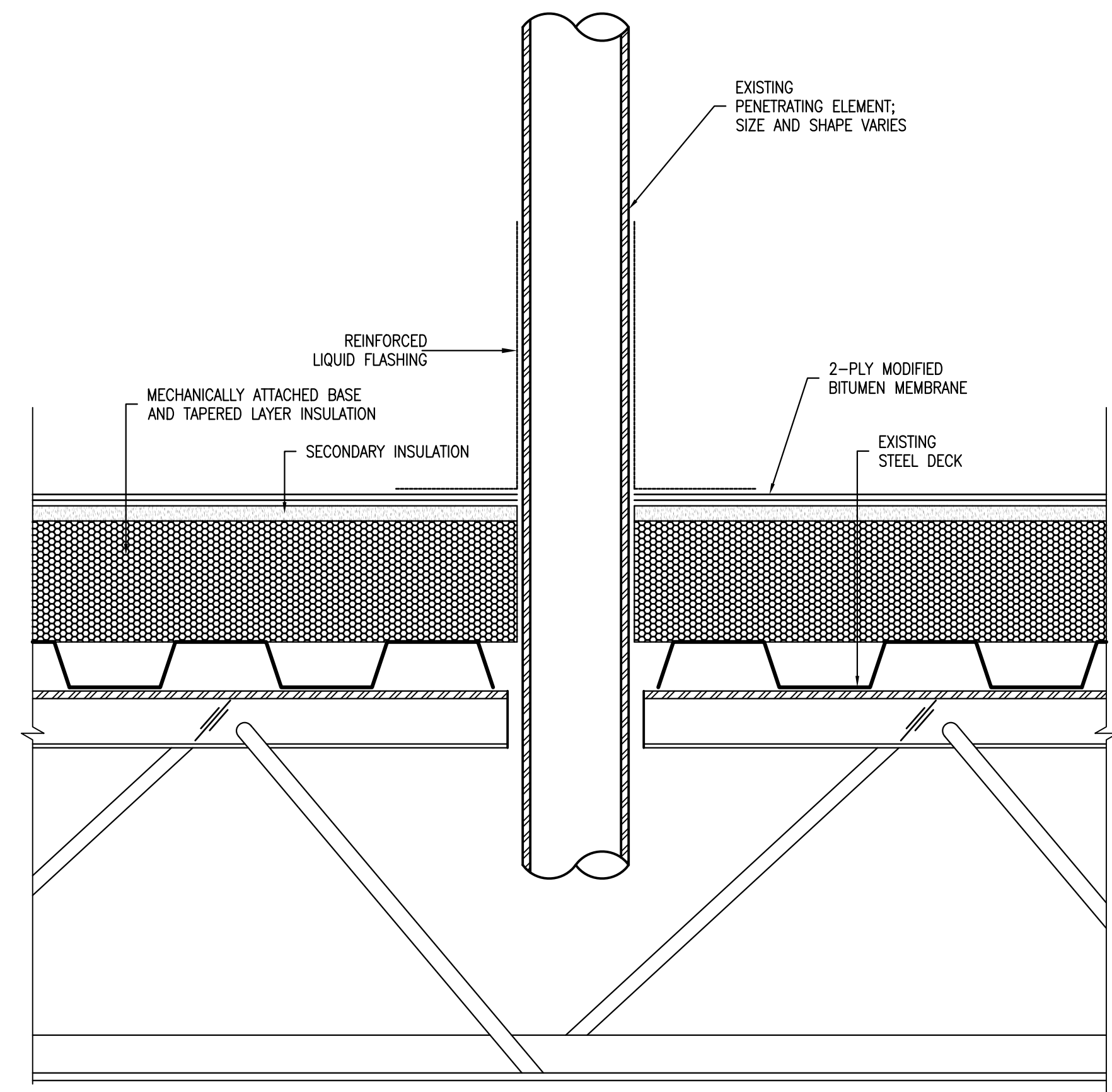

20 PENETRATION  
R5.02 SCALE: NOT TO SCALE

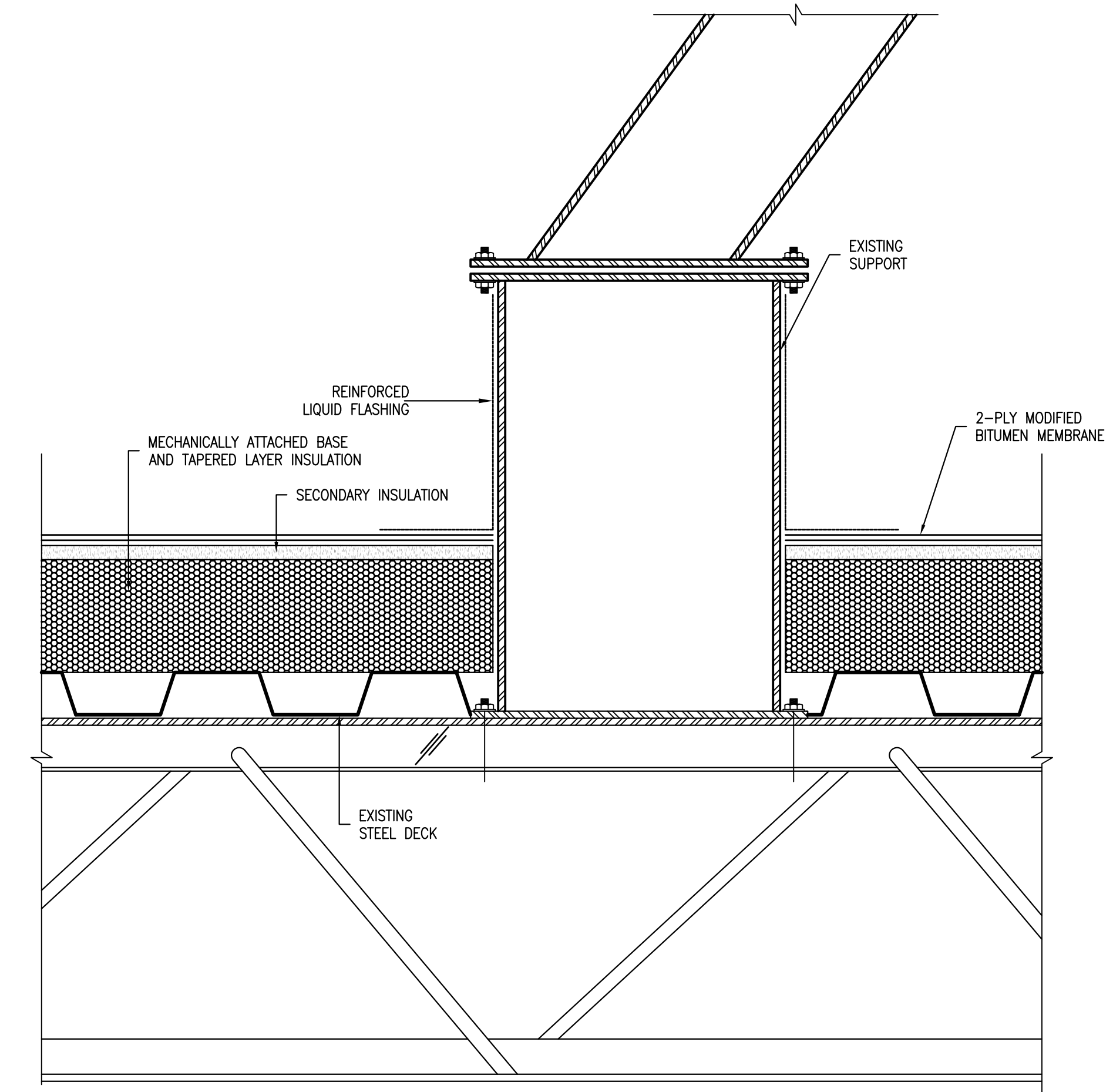

20 EQUIPMENT SUPPORT  
R5.02 SCALE: NOT TO SCALE (TYPICAL)

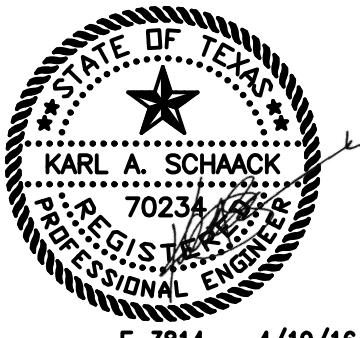

F-3814 4/19/16

**PRICE CONSULTING, INC.**  
PRICE CONSULTING, INC.  
211 HIGHLAND CROSS, SUITE 220  
HOUSTON, TEXAS 77073  
PHONE: (281)209-1724 FAX: (281)209-2724

PROJECT:  
UTHSC - SCHOOL OF NURSING  
6901 BERTNER AVE  
HOUSTON, TX

OWNER/CLIENT:  
UT HEALTH SCIENCE CENTER AT HOUSTON  
7000 FANNIN, UCT M125  
HOUSTON, TEXAS 77030

REVISIONS		
NO.	DATE	BY

DETAILS  
PCI PROJECT NO.: 11204.15  
PCI FILE NAME: R5.00-R5.02  
SCALE: AS NOTED

DWN.BY: DATE:  
ESG 04/19/16  
SHEET:  
R5.02