

NRC *newsletter*

<http://med.uth.edu/nrc>

News & Featured Research of the Neuroscience Research Center

volume 24, number 1, Summer 2018

Monet and Melanopsin

By David W. Marshak, Ph.D.



Marshak

Last January, my family and I went to The Museum of Fine Arts, Houston to see the exhibition Monet and the Seine: Impressions of a River. Monet had a houseboat-studio anchored on a tributary of the Seine near his home in Giverny. He woke up at 3:30 a.m., well before sunrise, and rowed to the Seine to paint exactly the same scene every morning. He worked on several canvases at once, each representing what he saw at different times of the day; pre-dawn, sunrise, early morning and late morning; and under a variety of weather conditions. The canvases were numbered, and he had an assistant put them up on the easel, in sequence, as he went along. Monet was very meticulous, taking the years 1896 and 1897 to complete a series of fifteen magnificent paintings. There are many different interpretations of what Monet was trying to accomplish with the Mornings on the Seine series, and they are not mutually exclusive. For example, he may simply have been trying to make a living. Many more French people were decorating their homes with oil paintings at that time, and landscapes were particularly popular. The exhibition including these paintings was very well-received by critics and financially successful.

After seeing a series of Monet's Mornings on the Seine paintings, I realized that they might provide some primary data about visual perception. Even though the paintings are somewhat abstract, I believe that Monet was systematically exploring the effects of light on the appearance of natural scenes and conveying what he really saw at different times of the day. In the paintings done earliest in the morning, Monet's rods and cones would have both been active. This would account for the predominance of blues and purples in

CONTINUED ON PAGE 6; MARSHAK

Seeing Night and Day

By John O'Brien, Ph.D.



O'Brien

Abstract: Our day-to-day experience of the visual world presents tremendous challenges to the visual system, which must accommodate huge changes in light intensity while providing the brain with information it can interpret. My lab is investigating retinal mechanisms that make this possible, with a focus on plasticity of electrical synapses. These mechanisms reconfigure neural networks to switch from nighttime to daytime vision and refine circuits to optimize their function at different light levels.

The natural world presents astounding challenges to our visual system. The intensity of light reflected off objects we can see may vary by ten orders of magnitude between a starlit night and a bright sunlit day. Nonetheless, we are able to make visual sense of the world throughout that range. A host of mechanisms makes this possible. One focus of research in my lab is to understand the synaptic and circuit mechanisms that operate as light intensity changes. In particular, we have focused on electrical synapses, whose dynamic changes in strength play a major role in adapting the retinal neural network to function optimally at different light levels.

In general, the visual intensity scale is split across two neural systems. The retinal rod system operates in dim light, with rod photoreceptors responding reliably to every single photon they absorb. This system is used for night vision. The retinal cone system requires much brighter light, but also extracts and encodes far greater information content from the visual scene. Both systems operate over many orders of magnitude of light intensity and require additional mechanisms to control detection sensitivity, the

CONTINUED ON PAGE 8; O'BRIEN

Director's Column

From the Director, John H. Byrne, Ph.D.



I was intrigued a few years ago when my colleague in the Department of Neurobiology and Anatomy at McGovern Medical School, David Marshak, a professor and retinal scientist, mentioned his fascination with the paintings of the Seine by Claude Monet. This issue of the newsletter features Dr. Marshak's personal essay, edited only for length, on a Monet exhibit he saw at the

Museum of Fine Arts-Houston and the questions it raised for him about the role of a protein in the retina called melanopsin. The newsletter also features the research of John O'Brien, professor in the Ruiz Department of Ophthalmology and Visual Science. He summarizes his laboratory's studies of our visual system's electrical synaptic network. I hope that even those of our readers who are not scientists themselves will find both articles stimulating. Each one could serve as a springboard for questions about the connections between basic science and the creative, interpretive brain.

On a practical note, I am pleased to report on recent activities of the Society for Neuroscience's (SfN) Government and Public Affairs (GPA) Committee. I became a member of the committee last year and find the experience enlightening and satisfying. Together with a delegation of southeast Texas SfN volunteers last spring, I joined the other GPA committee members and their delegations in Washington, D.C. for SfN's annual "Capitol Hill Day" on March 8th. Our purpose was to present the case for robust and consistent federal investment in biomedical and neuroscience research. We wanted to gain or solidify congressional support for increasing the Fiscal Year 2018 funding for both NSF and NIH over that of FY 2017's levels (as well as increases in funding for 2019 over 2018). Overall, our committee members and delegations of volunteers—from 25 states and six countries—held over 90 meetings with senators and representatives or their staff members. Joining us in our mission were advocates from other biomedical organizations, as well.

Our SfN group devoted our time before Hill Day to prepare. Among ourselves, we discussed recent advances in neuroscience, the potential of research findings for leading to new treatments and cures, and the many reasons for increased and consistent federal investment in NIH and NSF. The next day, SfN formally presented its Public Advocacy Awards to Sen. Roy Blunt and Rep. Tom Cole, each of whom had shown strong support for NIH and NSF funding requests in their positions as chairmen of the respective Senate and House Appropriations Subcommittees on the Departments of Labor, Health and Human Services, Education, and Related Agencies.

In addition to our session with the award winners, my delegation met with Rep. Pete Sessions, chair of the House Rules Committee, and Rep. John Culberson, a member of the House Appropriations Committee and chair of the Subcommittee on Commerce, Justice, and Science, which has jurisdiction over the NSF. Both of them were very supportive

of biomedical research funding. We also visited with staff members of Sen. John Cornyn, Rep. Al Green, Rep. Ted Poe, and Rep. Randy Weber.

Fortunately, research funding is a nonpartisan issue, especially in such fields as neuroscience, because, of course, it affects all people throughout life (and before birth). Our meetings on the hill were extremely pleasant, and when the day was done, my assessment was that our efforts, combined with those of the other advocacy groups who were there, would surely contribute to a positive outcome.

Indeed, as you likely well know, the FY 2018 Omnibus Appropriations Act that was passed by Congress and signed by the president soon after Hill Day, included substantial increases in funding for FY 2018 over FY 2017, for both NIH and NSF. NIH received a \$3 billion increase, bringing its total funding to \$37.08 billion. NSF's total funding was increased to \$7.8 billion, primarily due to a \$301 million increase for "Research and Related Activities," the budget category of our greatest interest.

Several weeks after the appropriations bill was passed, Rep. Culberson participated in a panel discussion that McGovern Medical School hosted on the future of funding for biomedical research. Administrators from leading institutions in Houston's Texas Medical Center (TMC) served on the panel, together with moderator John Hancock, Ph.D., chair of the Department of Integrative Biology and Pharmacology and vice-dean of research at McGovern Medical School, as well as executive director of the Brown Foundation Institute of Molecular Medicine at UTHealth. Rep. Culberson noted there is much support in Congress for research funding in FY 2019, but he also said the availability of funds in subsequent years is questionable, and he is concerned about competing and escalating demands. The congressman is visiting the TMC again in August to tour some of our research labs, including my own. I am looking forward to it and to my continued service on the GPA Committee through the coming year.

Notwithstanding the critical importance of funding for neuroscience research, any picture of the investment required for a thriving research enterprise is fundamentally flawed if we do not include the science education of children. That is why the NRC reaches out each year to families with children in kindergarten through 5th grade with our program Brain Night for Kids. Held March 15th at the McGovern Museum of Health & Medical Science, the program attracted hundreds of families and kids with dozens of activities.

The NRC held its 2018 Public Forum at the Cooley University Life Center on May 12th. This year's program, titled *New Approaches for Transforming the Course of Parkinson's Disease*, drew a large audience, including people who have Parkinson's, family members, caregivers, and others. Mya Schiess, M.D., professor of neurology and director of the Movement Disorders and Neurodegenerative Diseases Clinic Fellowship Program at McGovern Medical School, led a discussion with four UTHealth

panelists: Allison Boyle, M.D., assistant professor of neurology; Richard Castriotta, M.D., professor and medical director of the Sleep Disorders Center at Memorial Hermann-Texas Medical Center; Herbert DuPont, M.D., professor of infectious diseases and holder of the Mary W. Kelsey Distinguished Chair; and Monica Verduzco-Gutierrez, M.D., assistant professor of physical medicine and rehabilitation and medical director of the Brain Injury and Stroke Programs at TIRR Memorial Hermann.

The NRC was delighted to have Martha J. Farah, Ph.D. deliver our 2018 Distinguished Lecture in the Neurosciences in February. Dr. Farah is the Walter H. Annenberg Professor in the Natural Sciences at the University Of Pennsylvania and director of the university's Center for Neuroscience & Society.

She spoke on Socioeconomic Status and Brain Development: From Science to Policy, an unusual topic for this program and very well received.

In closing, I have a few thoughts in memory of a longtime NRC friend and former UTHealth colleague, Raymond J. Grill, Ph.D., who passed away May 30th. He was a faculty member in integrative biology and pharmacology and an active researcher, primarily focused on spinal cord injury. He generously gave his time to assisting with NRC programs. Most notably, he served as editor of the NRC Newsletter for four years, 2011 to 2015, when he left UTHealth to join the the faculty of University of Mississippi Medical Center. I was grateful for his many contributions to the NRC, and the world will miss him.



Visiting Rep. Pete Sessions on March 8 are (around the table left to right) Melanie Samuel/Baylor College of Medicine, Sanjeev Khatriwada/Baylor College of Medicine, Jack Byrne/UT Health NRC, Rep. Sessions, and Tim Folorunso/University of Texas Medical Branch at Galveston; on sofa (far left to right) are Rick Haganir, SfN president; Diane Lipscombe, SfN president-elect; and Marty Saggese, SfN executive director. (photo provided by SfN)

Rep. John Culberson (far left) talks about neuroscience research with members of the SfN Texas delegation; from congressman's left to right are Rick Haganir, SfN president; Tim Folorunso/University of Texas Medical Branch at Galveston; and Jack Byrne/UT Health NRC. (photo provided by SfN)



news & information

Jaroslav Aronowski, M.D., Ph.D., professor and Roy M. and Phyllis Gough Huffington Chair in Neurology at McGovern Medical School, has received an exploratory/developmental research grant from NIH/NINDS to develop a regimen of dimethyl fumarate (DMF) for intracerebral hemorrhage (ICH) in animal models. There are currently no treatments for ICH, which has the highest mortality rate of all stroke types. **Sean I. Savitz, M.D.**, professor and the Frank M. Yatsu Chair in Neurology, is also a PI on the grant. Their research group has found that DMF, a recently approved oral therapy for multiple sclerosis, detoxifies blood products, protects against oxidative stress, and reduces inflammation, hematoma size, and neurological disorders.

John H. Byrne, Ph.D., professor and June and Virgil Waggoner Chair in Neurobiology and Anatomy at McGovern Medical School, received two NIH/NINDS grants: “Modeling the Molecular Networks that Underlie the Formation and Consolidation of Memory” and “Analyses of the Distributed Representation of Associative-Learning in an Identified Circuit Using a Combination of Single-Cell Electrophysiology and Multicellular Voltage-Sensitive Dye Recordings.” Dr. Byrne also received a competitive renewal of an NIH grant, “Analysis of the Neural Control of Behavior,” bringing the research into its 42nd year of continuous funding.

With funding from a public/private partnership, **Charles S. Cox, Jr., M.D.**, professor of pediatric surgery, the George and Cynthia Mitchell Distinguished Chair in Neurosciences, and co-director of the Red Duke Trauma Institute at Memorial Hermann-Texas Medical Center, is leading the first clinical trial of stem cell therapy for early treatment after severe traumatic injury. Funding includes \$2 million from the Medical Technology Consortium and \$1.5 million from Memorial Hermann Foundation, together with NIH funds for the pediatric trial and Department of Defense funds for the adult trial.

Breno Satler Diniz, M.D., Ph.D., assistant professor of psychiatry at McGovern Medical School, received a grant from the NIH/NIMH small grant program to study novel pathophysiological mechanisms in older adults with depression, identify associated structural changes in the brain, and identify novel potential targets for the development of interventions to treat depression and prevent related negative outcomes.

Rodrigo Hasbun, M.D., M.P.H., professor of medicine at McGovern Medical School, received a two-year grant from BioMérieux Inc. for an observational study evaluating the potential clinical impact of the BioFire® meningitis and encephalitis panel in adults and children with meningitis and encephalitis.

Dong H. Kim, M.D., professor and chair of The Vivian L. Smith Department of Neurosurgery at McGovern Medical School and director of the Mischer Neuroscience Institute, has received an NIH/NINDS grant titled “Role of THSD1 and its Disease Causing Variants in Intracranial Aneurysm.”

David W. Marshak, Ph.D., professor of neurobiology and anatomy at McGovern Medical School, has received a subcontract as a consortium principal investigator on an NIH/NEI grant, “Linking Retinal Circuits to Perception,” awarded to Jay Neitz, Ph.D., at the University of Washington.

Louise D. McCullough, M.D., Ph.D., professor, Roy M. and Phyllis Gough Huffington Distinguished Chair, and chair of the Department of Neurology at McGovern Medical School, received a \$3.7 million NIH/NIA grant to examine how the gut’s microbiome influences the onset and progression of cerebral amyloid angiopathy. She also received an NINDS grant to study the effects of manipulations of the microbiome on stroke recovery in aged mice. Dr. McCullough was inducted last spring into the Society of Scholars at Johns Hopkins University. Hilda W. Ahnstedt, Ph.D., a postdoctoral research fellow in Dr. McCullough’s lab, received an Elizabeth Young New Investigator Award for 2018 from the Organization for the Study of Sex Differences for her study on sex differences in T cell immune responses, gut function, and behavioral outcome after ischemic stroke in aged mice.

Rodrigo Morales, Ph.D., assistant professor of neurology at McGovern Medical School, received two grants. One is from the Alzheimer’s Association for his study of the shape of beta-amyloid and how it contributes to the progression of Alzheimer’s in mouse models. The other award is from the Creutzfeldt-Jakob Disease Foundation to assess the potential for chronic wasting disease isolates to be transmitted from animals to humans.

Ponnada Narayana, Ph.D., professor of diagnostic and interventional imaging at McGovern Medical School, received an NIH/NINDS grant to identify active lesions in multiple sclerosis patients, without necessarily using MRI gadolinium-based contrast agents (GBCAs), due to safety concerns with repeated administration of GBCA. Instead, texture analysis, using multi-modal non-contrast MRI and support vector machine learning will be done in real time. The high performance computational resources located at the Texas Advanced Computing Center in Austin, TX will be used in the project.

John O'Brien, Ph.D., professor and the Louisa Stude Sarofim Distinguished Chair in Ophthalmology in the Richard S. Ruiz Department of Ophthalmology and Visual Science at McGovern Medical School, received an NIH/NEI grant for the development of animal models to examine electrical synaptic plasticity in retinal neural networks and throughout the central nervous system. Dr. O'Brien also was awarded \$1 million from the William Stamps Farish Fund to investigate the process, in zebra fish, of re-growing neurons in the retina from progenitor cells.

Sunil A. Sheth, M.D., assistant professor of neurology at McGovern Medical School, received the 2018 Clinician-Scientist Development Award in Interventional Neurology from the American Academy of Neurology. The award provides \$240,000 over three years for his research on criteria to determine whether a stroke treatment that removes blood clots may be used. The treatment is currently reserved for patients within six hours of their stroke and after the analysis of advanced brain imaging studies, not widely available.

Nitin Tandon, M.D., professor of neurosurgery at McGovern Medical School and director of the epilepsy surgery program at Memorial Hermann-Texas Medical Center, received a grant for a Medtronic-sponsored three-year trial of selective laser ablation in temporal lobe epilepsy. Also, Kiefer Forseth,

a student advisee of Dr. Tandon's, received an Individual Predoctoral National Research Service Award M.D./Ph.D. Fellowship from the National Institute on Deafness and Other Communication Disorders.

Akihiko Urayama, Ph.D., assistant professor of neurology at McGovern Medical School, has received two grants. One is from the NIH/NINDS for studies of the blood-brain barrier related to the delivery of drugs to the brain. The other grant is from the NIH/NIA to investigate how cerebrovascular basement membrane fibrosis contributes to cognitive decline, the impaired clearance of beta-amyloid, and the development of cerebral amyloid angiopathy in mice.

In Other News...

UTHealth has opened its new Center for Advanced Microscopy, a Nikon Center of Excellence, (<https://med.uth.edu/libp/cytodynamic-imaging-facility>), the only one in Texas. Featuring state-of-the-art imaging capabilities, the center directly supports the McGovern Medical School Department of Integrative Biology and Pharmacology and is available as well for researchers throughout UTHealth and the Texas Medical Center.



Winners of the 2018 Distinguished Medical Student in the Neurosciences were (left) Cihan Mehmet Kadipasaoglu and (right) David James Savage. Dr. Byrne recognized the winners for their "outstanding research, education, and potential in the neurosciences" at the NRC's Public Forum on May 12. Winner of the 2018 Graduate Student Brain Awareness Outreach Award was Ryan Baumert (not present at the event).



*Morning on the Seine, Giverny, Claude Monet, 1897. This work shows the day's earliest emergence, "when the sun has barely begun to rise and the light is only a promise of what is to come," as described in the exhibition catalogue.**



*Arm of the Seine near Giverny, Claude Monet, 1897. This painting shows exactly the same setting along the river as in Morning on the Seine, Giverny. However, it was painted later in the morning and shows details that are visible in the late morning's clear and bright light.**

*Reprinted with permission of The Museum of Fine Arts, Houston from *Monet and the Seine: Impressions of a River*, by Helga Kessler Aurisch and Tanya Paul, 2014, Houston: Museum of Fine Arts/Yale University Press. The book accompanied the Museum of Fine Arts, Houston's exhibition, October 26, 2014 - February 1, 2015.

those paintings and for the absence of fine details. We and others have shown that signals from the rods activate the neurons that respond to blue light in addition to those that respond to black and white stimuli. Stimulation of the rods would be interpreted by the visual cortex as blue. This is why photographs in twilight never capture the vivid blue of the sky that we perceive. It is not really that blue, but our rods make it appear that way.

After sunrise, the rods saturate, and the cones predominate. This would explain why more reds and oranges appear later in the series. But the cones would quickly adapt to the ambient light intensity, and Monet would have not noticed that the absolute intensity of the light had changed. If rods and cones were the only photoreceptors, there should have been no further changes in the appearance of the scene as the day progressed, except for the direction of the light and the appearance of the shadows. However, there is a dramatic change in the paintings from later in the morning. Bright greens tend to predominate, and many more details are visible, particularly small movements such as ripples in the water. The color of sunlight changes as the angle between the sun and the horizon increases, and the wind tends to come up later in the day, and these things would all be visible using cones. But I believe that some of the other changes Monet saw were attributable to an increase in the activity of intrinsically-photosensitive retinal ganglion cells (IPRGCs), one of the many types of neurons whose axons travel to the brain in the optic nerve.

The continuous, rapid firing of the IPRGCs would generate a sustained release of dopamine, and this might account for the changes in the color palette. It might also explain why fine details and subtle movements in the periphery became more apparent as the morning progressed. The photopigment in IPRGCs is relatively insensitive to light, and bright, mid-

CONTINUED ON PAGE 10; MARSHAK

In the Spotlight

Left: Dr. Byrne and (center) Samantha Debes, a student in the MD Anderson UTHealth Graduate School of Biomedical Sciences (GSBS), are interviewed on a FOX 26 TV News program, March 15th, about the Brain Night for Kids event that evening. Center: A Brain Night visitor looks at an image of neurons, with Renan Costa, a GSBS student. Right: Girl holds a human brain.



Panelists for the NRC Public Forum on Parkinson's disease, held May 12, were (from left) Monica Verduzco-Gutierrez, M.D.; Richard J. Castriotta, M.D.; Mya C. Schiess, M.D., panel moderator; Herbert L. DuPont, M.D.; and Allison Boyle, M.D.

The invited speaker for the NRC's Distinguished Lecture in the Neurosciences was Martha J. Farah, Ph.D., professor at the University of Pennsylvania. She spoke at UTHealth on Feb. 22.



UTHealth faculty, students, post-docs, and colleagues at NRC's reception at the Society for Neuroscience Conference, Nov. 11-15, 2017 in Washington, D.C.

gain of synapses, and even the selection and activation of the neural circuits that will ensure useful vision as light intensity changes.

In seeing at night, we are the beneficiaries of our ancestors' evolutionary misfortune. Because early mammals were unable to compete in daytime with the more advanced dinosaurs, they retreated to nocturnal lifestyles. During this 150 million year "nocturnal bottleneck," mammals evolved some features that made seeing at night more feasible. Among these is a unique circuit in the rod pathway that increases its sensitivity to light. In all vertebrates, the primary cone pathway carries signals from cone photoreceptors to the first-order excitatory neurons, the bipolar cells, and then to the second-order excitatory projection neurons, the retinal ganglion cells, which carry information to the rest of the brain. In most vertebrates, the rod pathway parallels this organization, but in mammals an intermediate cell has been inserted: the AII amacrine cell. These cells receive input from the dedicated rod bipolar cell and direct that input into several types of cone bipolar cells, thereby piggybacking on the cone pathway. (See Figure 1.) In this pathway, information from many rods converges onto each rod bipolar cell, and then, many rod bipolar cells converge onto each AII amacrine cell. The AII amacrine cell thus pools signals from a large number of rods, which increases absolute light sensitivity. Strong direct electrical communication among AII amacrine cells through electrical synapses (gap junctions) allows any one AII amacrine cell to pool signals from as many as 10-fold more bipolar cells than it contacts directly and up to 100-fold more photoreceptors than a single rod bipolar cell contacts. The pooled signals are sent to each cone bipolar cell that contacts the AII amacrine cell, resulting in a large gain of sensitivity in the dimmest light. However, this sensitivity gain comes with a compromise of spatial resolution: The regions of visual space coded by

adjacent ganglion cells and sent to the rest of the brain overlap, blurring the visual representation.

As light becomes more abundant and the cone pathways take over, the compromise in spatial resolution can be a problem. While the AII amacrine cell serves a useful purpose in bright light-driven cone pathways, its strong electrical coupling is a hindrance. Among the mechanisms that enable the retina to adapt to well-lit environments is a dramatic reduction in electrical synaptic coupling among AII amacrine cells, which converts its function from a broad integrating circuit to a narrowly-refined local circuit. My lab has studied this process extensively. We identified

modifications of the gap junction protein, Connexin 36 (Cx36), that control its coupling, and subsequently identified components of the signaling cascade that reduces coupling as the retina adapts to bright light. Graduate student Wade Kothmann, currently a lecturer at American University in Washington, DC, worked out in detail the light- and dopamine-dependent signaling cascade that reduces coupling in AII amacrine cells, settling a decades old question in visual science (Kothmann et al. 2009, *J. Neurosci.* 29:14903-14911).

When we walk from the UTHealth McGovern Medical School across the street on a sunny Houston afternoon

Figure 1. Convergent Wiring of the Mammalian Rod Pathway

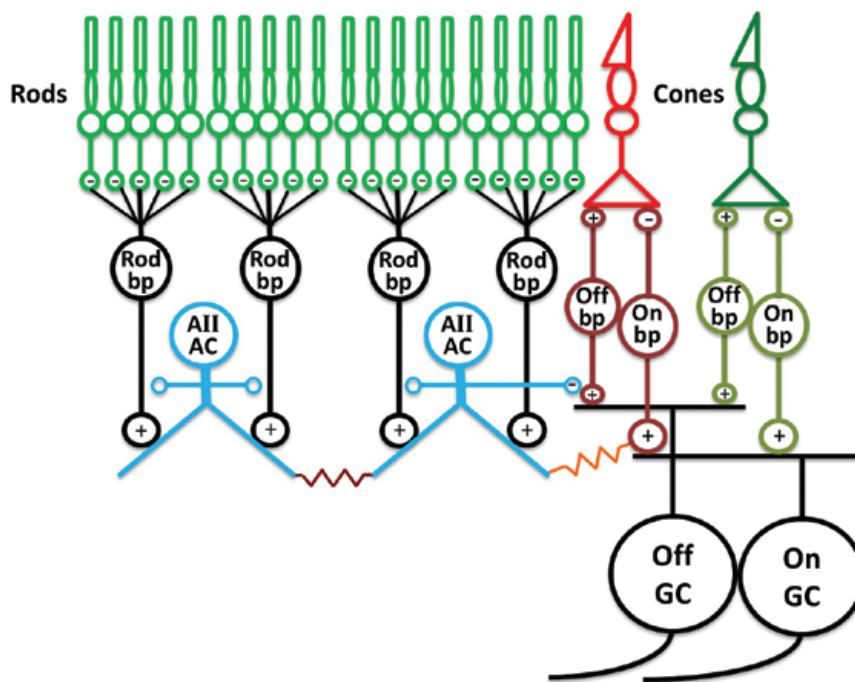

Many rods (green) contact each rod bipolar cell (rod bp). Several rod bipolar cells contact each AII amacrine cell (AII AC). AII amacrine cells spread excitatory signals (+) through electrical synapses () to each other and to cone On bipolar cells (On bp). AII amacrine cells inhibit (-) cone Off bipolar cells (Off bp) and Off ganglion cells (Off GC). The system gains sensitivity by pooling in three stages, resulting in your ability to detect 2-3 photons per 1000 rods at night. In bright light, electrical synaptic coupling is reduced, and the AII amacrine cell serves primarily a local circuit function to inhibit the Off bipolar cells when the On bipolar cells are excited, thus enhancing contrast.

to take in a seminar at Baylor College of Medicine, we think relatively little of adapting to the 6 or so order of magnitude drop in light level that we encounter in the space of 5 minutes. But our retina is hard at work to make vision possible. These dynamic changes in the visual environment demand responsive synaptic adaptation mechanisms. Indeed, coupling among AII amacrine cells is highly dynamic. In bright light, coupling is very low, but when the light dims, coupling can increase again within just a few minutes. In his graduate studies, Dr. Kothmann found that increases in coupling in dim light were not due simply to a reversal of the pathway that reduces coupling in bright light. Instead, the changes in coupling arose from an altogether different process. To identify this pathway, he keyed in on a curious feature of light adaptation in the AII amacrine cells: The cells lose coupling after they have adapted to complete darkness for a while, but regain it with just dim light exposure. The requirement for some light to support extensive coupling suggested an activity-dependent process. What Dr. Kothmann found was a process involving NMDA-type glutamate receptors, calcium influx, and protein phosphorylation—similar in some ways to the long-term potentiation of chemical synapses that occurs during learning and memory. The result is to effectively increase coupling in minutes (Kothmann et al. 2012, *J. Neurosci.* 32:6747-6759).

While activity-dependent potentiation of electrical synapses was a novel finding for mammals at the time of this research, the hallmarks of this signaling mechanism have subsequently been detected throughout the mammalian central nervous system. Our studies of several neural networks have revealed that the mechanisms that control electrical synaptic coupling in different neuron types may differ in key details. To better understand this complexity, we wished to study the dynamics and regulation of the calcium signaling mechanisms in more detail. To do this, we developed a biosensor for the calcium microdomain in the vicinity of electrical synapses. Dr. Keith Moore, a postdoctoral research fellow in my lab, showed that this biosensor, a genetically-encoded calcium indicator (GCaMP3) fused to gap junction protein Cx36, robustly reports calcium changes in cultured cells localized to the gap junctions. He further showed that we could model in the cell culture some of the synaptic processes involved in the adaptation of retinal neurons to light and dark conditions.

Our goals for this biosensor were centered on endogenous electrical synapses in the central nervous system. To this end, we developed a transgenic mouse that expresses our biosensor, which localizes to gap junctions in the retina and other parts of the brain and shows strong fluorescent calcium responses to certain types of stimuli. We are now able to image calcium dynamics at electrical synapses in living tissue preparations. We have planned a wide range of

experiments to examine how calcium signals reach electrical synapses in different types of neurons.

One notable challenge for this research is that natural electrical synapses are extremely small, generally under one micron in diameter in most types of neurons. This means that fluorescence from these small clusters is weak and difficult to distinguish from background noise. To overcome this difficulty, we have recently implemented a form of superresolution microscopy that is compatible with real-time imaging. Using a sensitive EMCCD (Electron-Multiplying Charge-Coupled Device) camera and SRRF (SuperResolution Radial Fluctuations) algorithms we are able to record several times as many Cx36-GCaMP3 electrical synapses in retinal slices as we could previously, while maintaining approximately one-second time resolution. These technical improvements will facilitate experiments in the future.

While detailed molecular studies of electrical synapse plasticity may seem esoteric, they can lead to many useful applications. Neuronal gap junction coupling plays a large role in secondary cell death subsequent to traumatic and ischemic brain injuries. Excessive coupling is believed to have a major role in seizures. Impaired coupling has also been proposed to be a contributing factor in autism spectrum disorder. A detailed understanding of the mechanisms that control electrical coupling will facilitate development of pharmacological methods to preserve function in brain injuries, mitigate seizure, and perhaps improve function in autism.

About the Author

John O'Brien, Ph.D. is a professor and holds the Louisa Stude Sarofim Distinguished Chair in Ophthalmology in the Richard S. Ruiz Department of Ophthalmology and Visual Science at McGovern Medical School. He is also a faculty member of the neuroscience and biochemistry and cell biology programs at the MD Anderson Cancer Center UTHHealth Graduate School of Biomedical Sciences. Dr. O'Brien earned his Ph.D. degree in biochemistry from the University of California at San Diego and joined UTHHealth in 1998. His research has focused on revealing the molecular mechanisms that control plasticity of electrical synapses and their role in visual adaptation. Recent projects have expanded his research scope to examine methods for restoring vision to degenerated retina through regeneration of photoreceptors from endogenous progenitor cells and introduction of light-sensitive channels in other neurons. For inquiries, contact him at John.O'Brien@uth.tmc.edu.

morning light on a clear day would be required to activate it maximally.

My interest in IPRGCs dates back to the fall of 2000. We had invited Dr. David Berson from Brown University to give a seminar about his research on the anatomy and physiology of retinal ganglion cells. We were unprepared for the revelation at the end of his talk. He had found that one type of mouse retinal ganglion cell expressed a photopigment and generated responses to light without any input from other retinal neurons. The responses mediated by the photopigment were relatively insensitive and had slow kinetics, beginning after a long delay and outlasting the stimulus by minutes. These intrinsically-photosensitive ganglion cells projected to the hypothalamus, where they provided the visual input to synchronize the master circadian clock in the brain with the daily changes in illumination.

In retrospect, we should not have been surprised. In 2000 Dr. Ignacio Provencio, now at the University of Virginia, isolated the photopigment, called melanopsin, and localized it to a subset of retinal ganglion cells in rodent and primate retinas. Furthermore, he suggested that these ganglion cells projected to the hypothalamus, providing an explanation for the ability of otherwise blind humans and other animals to entrain their circadian clocks to light even though all their rods and cones had degenerated. But I am particularly interested in recent findings that IPRGCs project to targets within the retina and contribute to conscious perception of light and image-forming vision.

A study by Dr. Dennis Dacey of the University of Washington and his collaborators showed that the IPRGCs of monkeys also project to the lateral geniculate nucleus of the thalamus, a relay for signals to the visual cortex. These ganglion cells responded to increments in dim stimuli, indicating that they received input from rods.

At higher light intensities, the polarity of their responses depended on the wavelength of the stimulus suggesting that they contributed to color perception. In collaboration with the Dacey Laboratory, we also showed that IPRGCs of macaque retina received inputs from bipolar cells and amacrine cells that would account for these responses. A second study of human color perception by Dr. Brian Wandell and his colleagues at Stanford University provided direct evidence for a contribution by melanopsin to human vision.

Previously, mammalian retinal ganglion cells were thought to make synapses only in the brain, but it now appears that IPRGCs make synapses within the retina. There is now considerable, but indirect, evidence that their targets include dopamine-releasing amacrine cells. The retina is able to work over an enormous range of ambient light intensities, and to accomplish this, the neural circuits have to change in subtle ways as the illumination changes. Dopamine plays an important role in this process, changing the strength of chemical and electrical synapses on virtually every type of retinal neuron. But, until recently, it was unclear how the dopaminergic amacrine cells could detect the absolute intensity of the ambient light because the rods and cones adapt, themselves.

We now know that melanopsin enables the IPRGCs to transmit information about the absolute intensity of light stimuli. In primate retinas, contacts between intrinsically-photosensitive ganglion cells and dendrites of dopaminergic cells have been observed. The synapses made by the axons of intrinsically-photosensitive ganglion cells have never been observed in the electron microscope, however, and we are beginning experiments to accomplish that.

Studies of the role of melanopsin in human visual perception are just beginning, however, and a lot more

work will need to be done to understand how much it affects our vision. Does a fourth visual pigment in the peripheral retina influence our perception of color? Do the IPRGCs contribute to the perception of form and movement? To answer these questions we will need to design modern versions of Monet's experiments from 1897.

About the Author

David Marshak, Ph.D., is a professor in the Department of Neurobiology and Anatomy at the UTHealth McGovern Medical School. He first became interested in vision as an undergraduate at Cornell University, where he received a B.A. in anthropology; he studied the retina as a graduate student at UCLA. After receiving a Ph.D. in anatomy, he continued as a postdoctoral fellow at the Biological Laboratories at Harvard and joined the faculty of UTHealth in 1984. Since then, he and his collaborators have been studying the structure and function of the primate retina. The focus of their current grant from the National Eye Institute is on the neurons that process signals from blue cones, including the retinal ganglion cells that express melanopsin.

Upcoming Events

Neurobiology of Disease Seminar Course

Current Topics in the Neurobiology of Disease: "Epigenetics of Brain Disorders"
UTHealth NRC and MD Anderson UTHealth Graduate School of Biomedical Sciences

Course Directors: **Consuelo Walss-Bass, Ph.D.**, Associate Professor of Psychiatry and Behavioral Sciences, UTHealth;
John Byrne, Ph.D., NRC Director and Professor of Neurobiology and Anatomy, UTHealth

Mondays, August 27 to December 17, noon to 1:00p.m.

UTHealth McGovern Medical School Building, 7.037
6431 Fannin St, Houston, TX 77030

For details, contact Donna Wood at the NRC (donna.wood@uth.tmc.edu or 713-500-5633)

Neuroscience Poster Session

Saturday, December 1, 2018

UTHealth Cooley University Life Center
7400 Cambridge St., Houston, TX 77054

Check the NRC website (<https://med.uth.edu/nrc>) for information or email us at nba-nrc@uth.tmc.edu.

Save the Date – April 4, 2019

UTHealth NRC 2019 Distinguished Lecture in the Neurosciences

Leslie G. Ungerleider, Ph.D.
Chief, Laboratory of Brain and Cognition
National Institute of Mental Health
NIH Distinguished Investigator

UTHealth McGovern Medical School Building, 3.001
6431 Fannin St, Houston, TX 77030

Check our online calendar at <https://med.uth.edu/nrc/eventcal/> for other events at UTHealth and elsewhere in the Texas Medical Center and surrounding area. We welcome notices of your neuroscience events (seminars, grand rounds, research colloquia, symposia, and other local or national conferences sponsored by UTHealth, the Texas Medical Center, and Houston area universities and research institutions). Submit the event name, contact information, date, time, and location in an email to nba-nrc@uth.tmc.edu.



**Neuroscience
Research Center**

6431 Fannin St., MSB 7.046
Houston, TX 77030

NONPROFIT ORG.
U. S. POSTAGE
PAID
HOUSTON, TX
PERMIT NO. 209

ADDRESS SERVICE REQUESTED

Keep in Touch!

Website: <http://med.uth.edu/nrc>

facebook

"Like" UTHealth Neuroscience Research Center at
www.facebook.com/UTHealthNRC



@UTHealthNRC; www.Twitter.com/UTHealthNRC

Questions? Comments?

Contact us at 713-500-5538
or E-mail: nba-nrc@uth.tmc.edu

This Newsletter is distributed by mail to individuals and groups engaged in neuroscience research within the TMC and worldwide and features research, neuroscience accomplishments and outreach efforts performed at UTHealth. Past issues are available on the NRC website.

If you prefer to receive a digital copy through email, please contact nba-nrc@uth.tmc.edu with your information.

The Neuroscience Research Center Newsletter

Editor: Anne J. Morris, Ph.D.

Assistant Editor: Paul D. Smolen, Ph.D.

Design: Jeremy Buzek, UT Printing & Media Services

The Neuroscience Research Center is a component of
The University of Texas Health Science Center at Houston.

Director: John H. Byrne, Ph.D.

Editor: Anne J. Morris, Ph.D.

Assistant Editor: Paul D. Smolen, Ph.D.

Sr. Coordinator, Special Programs: Donna Wood

Executive Committee:

Michael R. Blackburn, Ph.D.

John H. Byrne, Ph.D.

Pramod Dash, Ph.D.

Linda Ewing-Cobbs, Ph.D.

Amy Franklin, Ph.D.

Ralph Frankowski, Ph.D.

Cameron Jeter, Ph.D.

Louise McCullough, M.D., Ph.D.

Ponnada A. Narayana, Ph.D.

Joy Schmitz, Ph.D.

Jair C. Soares, M.D., Ph.D.

Nitin Tandon, M.D.

The University of Texas
Health Science Center at Houston

President: Giuseppe N. Colasurdo, M.D.